



Keyboard User Manual

DISCLAIMER

Daisy Data Displays, Inc. (D3) makes no representations or warranties with respect to the contents or use of this manual, and specifically disclaims any express or implied warranties of merchantability or fitness for any particular purpose. Further, Daisy Data Displays, Inc. reserves the right to revise this publication and to make changes to its content, at any time, without obligation to notify any person or entity of such revisions or changes.

Further, Daisy Data Displays, Inc. makes no representations or warranties with respect to any D3 manufactured equipment, and specifically disclaims any express or implied warranties of merchantability or fitness for any particular purpose. Further, Daisy Data Displays, Inc. reserves the right to make changes to any and all D3 manufactured equipment, at any time, without obligation to notify any person or entity of such changes.

FCC WARNINGS

Computing devices and peripherals manufactured by D3 generate, use, and can radiate radio frequency energy, and if not installed and used in accordance with the instructions in this manual may cause interference to radio communications. Such equipment has been tested and found to comply with the limits for a Class A computing device pursuant to Subpart J of Part 15 of the FCC Rules, which are designed to provide reasonable protection against radio interference when operated in a commercial environment. Operation of this equipment in a residential area is likely to cause interference, in which case the user - at his own expense - will be required to take whatever measures may be required to correct the interference.

Some components may not have been manufactured by Daisy Data Displays, Inc. If not, Daisy has been advised by the manufacturer of the component that the component has been tested and complies with the Class A computing device limits as described above.

Copyright 2012 Daisy Data Displays, Inc. All rights reserved. No part of this publication may be reproduced, photocopied, stored on a retrieval system, or transmitted without express prior written consent.

Daisy Data Displays, Inc.
2850 Lewisberry Road
York Haven, PA 17370 USA
Phone: (717) 932-9999
Website: www.makeitdaisy.com

February 2015 Edition
Manual Revision 3.3
Part Number D005-000002-01

Limited Warranty and Liability Statement

To the original purchaser, Daisy Data Displays, Inc., hereinafter referred to collectively as SELLER, warrants each of its manufactured products, and all components therein contained to be free from defects in materials and/or workmanship for a period of 12 months from the date of purchase.

Should a malfunction, or other indication of defect attributable directly to faulty materials and/or workmanship occur, Seller will, at its option, and without charge to the customer for labor and parts, repair or replace the defective product, F.O.B. Seller's plant, but Seller will not be responsible for freight from Purchaser to Seller's plant.

In no event shall Seller be liable for any loss, inconvenience or damage, whether direct, incidental, consequential or otherwise resulting from abuse, misapplication or modification of the product, improper or faulty power, damage resulting from repairs or alterations performed by unauthorized persons, or conditions resulting from any other equipment attached to the product.

Seller assumes no liability for damage occurring in transit due to the product not being returned in its original shipping material.

This warranty is exclusive and is in lieu of any warranty of merchantability or fitness for a particular purpose or other warranty of quality whether expressed or implied, except of title and against patent infringement. Correction of nonconformities, in the manner and for the period of time provided above, shall constitute fulfillment of all liabilities of the Seller to the Purchaser with respect to, or arising out of the goods, whether based on contract, negligence, strict tort or otherwise.

LIMITATION OF LIABILITY: The Seller shall not under any circumstances be liable for special or consequential damages, such as, but not limited to, damage or loss of other property or equipment, loss of profits or revenues, cost of capital, cost of purchased or replacement goods, or claims of customers of Purchaser for service interruptions. The remedies of the Purchaser set forth herein are exclusive, and the liability of Seller respect to any contract, or anything done in connection therewith such as the performance or breach thereof, of from the manufacture, sale, delivery, resale, installation or use of any goods covered by or furnished under this contract whether arising out of contract, negligence, strict tort or breach of warranty or otherwise, shall not, except as expressly provided herein, exceed the price of the goods upon which such liability is based.

This warranty gives you specific legal rights, and you may also have other rights, which vary from state to state.

Seller makes every effort to provide clear and accurate technical information on the application of its products in the Operator's Manual, and assumes no liability for misuse of the information.

Table of Contents

1. Introduction 1
 1.1. Important Information 1
2. Keyboard Installation..... 4
 2.1. General Instructions 4
 2.2. Pointing Device Instructions..... 6
 2.3. Mounting Instructions for Panel Mounted Keyboards..... 8
 2.4. Mounting Instructions for Keyboard OEM Kits 8
 2.5. Installing Intrinsically Safe Keyboards..... 8
3. Special Notes on D3 60-Key Keyboards 18
 3.1. Standard 60-Key Output Codes 18
 3.2. Custom Software and Legends 18
 3.3. Changing Legends on the 60-Key Membrane Keyboard..... 18
4. Recommended Computer Peripheral Ergonomics Guide 20
5. Maintenance and Cleaning 22
6. Appendices 23
 6.1. Appendix A - Keyboard Specifications 23
 6.2. Appendix B – Connector Pinouts for Keyboards..... 25
 6.3. Appendix C – Connector Pinouts for Pointing Devices..... 26
 6.4. Appendix D – D3 Cable Wire Color Codes..... 27
 6.5. Appendix E – Barrier Assembly Drawings..... 28
 6.6. Appendix F – PS/2 Barrier Modifications for Compatibility Issues 34
 6.7. Appendix G – 9148 Current Limiting Kit Drawing..... 35
 6.8. Appendix H – 9122 & 9141 Keyboard Isolators 36
 6.9. Appendix I – Keyboard Model Illustrations 42

Table of Figures

Figure 1-1 NEMA 4X Keyboard Models..... 2

Figure 1-2 Intrinsically Safe Keyboard Models 3

Figure 2-1 Sealed Keyboard Connector Installation 10

Figure 2-2 Sealed Pointing Device Connector Installation 11

Figure 2-3 Cutout for 6002 / 6005 12

Figure 2-4 Cutout for 6812 / 6815 / 6912 / 6915 13

Figure 2-5 Cutout for 6822 / 6825 / 6922 / 6925 14

Figure 2-6 Cutout for 6832 / 6835 / 6842 / 6845 / 6932 / 6935 / 6942 / 6945 15

Figure 2-7 Cutout for 6002AM / 6005AH Keyboard OEM Kits 16

Figure 2-8 Cutout for 6812AA / 6815AA / 6912AA / 6915AA Keyboard OEM Kits..... 17

Figure 5-1 Sealed Trackball..... 22

Figure 5-2 Trackball Face Ring 22

Figure 6-1 Keyboard Connector Pinouts..... 25

Figure 6-2 Pointing Device Connector Pinouts..... 26

Figure 6-3 I.S. Keyboard Barriers in Barrier Kit Assembly..... 28

Figure 6-4 I.S. Pointer Barriers (Serial) in Barrier Kit Assembly 29

Figure 6-5 I.S. Pointer Barriers (PS/2) in Barrier Kit Assembly..... 30

Figure 6-6 I.S. Keyboard Barriers Installed in Enclosure 31

Figure 6-7 I.S. Pointer Barriers (Serial) Installed in Enclosure..... 32

Figure 6-8 I.S. Pointer Barriers (PS/2) Installed in Enclosure 33

Figure 6-9 Current Limiting Kit Diagram (9148) 35

Figure 6-10 - Isolator Diagram (9122)..... 36

Figure 6-11 Isolator Diagram (9141) 37

Figure 6-12 Keyboard Barrier Modifications..... 38

Figure 6-13 Keyboard Barrier Modifications..... 39

Figure 6-14 Pointing Device Barrier Modifications 40

Figure 6-15 Pointing Device Barrier Modifications..... 41

Figure 6-16 Illustration: 6000 / 6003 42

Figure 6-17 Illustration: 6002 / 6005 43

Figure 6-18 Illustration: 6002AM / 6005AH OEM Kits..... 44

Figure 6-19 Illustration: 6810 / 6813 45

Figure 6-20 Illustration: 6812 / 6815 46

Figure 6-21 Illustration: 6812AA / 6815AA OEM Kits 47

Figure 6-22 Illustration: 6820UN / 6823UN..... 48

Figure 6-23 Illustration: 6822UN / 6825UN..... 49

Figure 6-24 Illustration: 6830UN / 6833UN..... 50

Figure 6-25 Illustration: 6832UN / 6835UN..... 51

Figure 6-26 Illustration: 6840UN / 6843UN..... 52

Figure 6-27 Illustration 6842UN / 6845UN..... 53

Figure 6-28 Illustration: 6910 / 6913 54

Figure 6-29 Illustration: 6912 / 6915 55

Figure 6-30 Illustration: 6912AA / 6915AA OEM Kits 56

Figure 6-31 Illustration: 6920UN / 6923UN..... 57

Figure 6-32 Illustration: 6922UN / 6925UN..... 58

Figure 6-33 Illustration: 6930UN / 6933UN..... 59

Figure 6-34 Illustration: 6932UN / 6935UN..... 60

Figure 6-35 Illustration: 6940UN / 6943UN..... 61

Figure 6-36 Illustration: 6942UN / 6945UN..... 62

Figure 6-37 Illustration: 6950UN 63

1. Introduction

Thank you for purchasing a **D3** industrial keyboard! D3 keyboards are rugged, industrial computer peripherals specially designed for use in harsh and hazardous environments. Resistant to dust, hose-directed water, and most industrial chemicals, the keyboards are perfect for use in manufacturing plants, field facilities, and other applications demanding the most abuse-resistant equipment. All models are designed to NEMA 4X specifications and are available in Factory Mutual approved intrinsically safe models.

D3 keyboards are available in a wide range of configurations to meet your needs. A 60-key reduced footprint version is available in the membrane line, and can be configured with custom programming and legending. The full 109-key version is available either in a full travel elastomeric key model or a highly abuse-resistant membrane model. Mounting options include rack mount, panel mount, desktop, and drawer mount. Each 109-key line is also available with or without pointing device – TuffPoint, MicroModule, or MicroJoystick. OEM kits for each of the keyboard types is also available for integration into your product design.

A matrix of the available NEMA 4X models is shown in Figure 1-1, page 2. Intrinsically safe models are shown in Figure 1-2, page 3. Layouts of the various keyboard models are shown in section 6.9 beginning on page 42.

1.1. Important Information



WARNING! Continuous use of keyboards and pointing devices may lead to Repetitive Stress Injuries (RSIs) or related disorders. Please see our Recommended Computer Peripheral Ergonomics Guide in section 4 on page 20 for more information on reducing the risk of these injuries. If the keyboard and pointing device operator feels any aching, numbing, or tingling in the arms, wrists, or hands, the operator should immediately consult a qualified healthcare professional.











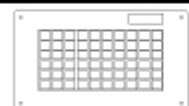



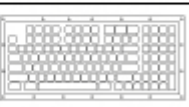
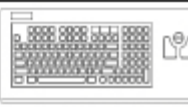

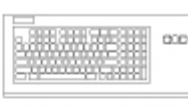



The following are suggestions to reduce the risk of RSI:

- Keep your wrists straight while typing or using the pointing device
- Use as light a touch as possible on the keys and pointing device
- Do not use your wrists to rest your hands while typing or using the pointing device
- Take frequent breaks from operating the keyboard and pointing device
- Maintain good health habits

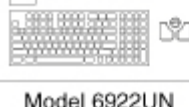
There are studies which indicate that repetitive motions combined with a poor work environment and incorrect work habits over a long period of time may lead to certain physical disorders such as Carpal Tunnel Syndrome, tendonitis, and tenosynovitis. The instructions in our Recommended Computer Peripheral Ergonomics Guide on page 20 may help you reduce the risk of developing one of these disorders.



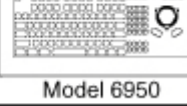

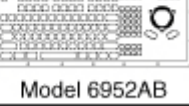





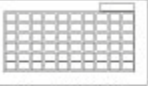

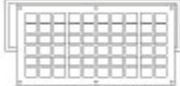
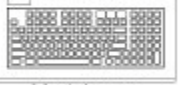

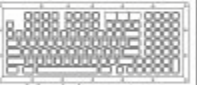

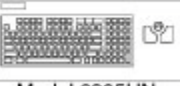





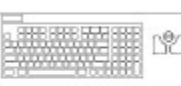

If you are not the end user of this equipment, or if others will be using this equipment, D3 strongly recommends that you post this information in a place where all potential operators of the equipment can refer to it. Please make any potential operators of this equipment aware of the possible risks of injury due to incorrect use, and the steps that they can take to reduce these risks.

Figure 1-1 NEMA 4X Keyboard Models

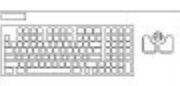
| Mounting Keyboard Type | Desktop | Panel Mount | OEM Kit |
|--|---|--|---|
| 60-Key Membrane |  Model 6000 |  Model 6002 |  Model 6002AM |
| 109-Key Elastomer |  Model 6810 |  Model 6812 |  Model 6812AA |
| 109-Key Elastomer w/TuffPoint |  Model 6820UN |  Model 6822UN | ✗ Not Available |
| 109-Key Elastomer w/MicroModule |  Model 6830UN |  Model 6832UN | ✗ Not Available |
| 109-Key Elastomer w/MicroJoystick |  Model 6840UN |  Model 6842UN | ✗ Not Available |
| 109-Key Membrane |  Model 6910 |  Model 6912 |  Model 6912AA |
| 109-Key Membrane w/TuffPoint |  Model 6920UN |  Model 6922UN | ✗ Not Available |
| 109-Key Membrane w/MicroModule |  Model 6930UN |  Model 6932UN | ✗ Not Available |
| 109-Key Membrane w/MicroJoystick |  Model 6940UN |  Model 6942UN | ✗ Not Available |
| 116-Key Membrane w/Trackball |  Model 6950 |  Model 6952 |  Model 6952AB |

Items Not to Scale

Figure 1-2 Intrinsically Safe Keyboard Models

| Keyboard Type \ Mounting | Desktop | | Panel Mount | OEM Kit |
|--|---|---|--|---|
| | Pointing Device Interface | | | |
| | Serial | PS/2 | | |
| 60-Key Membrane |  Model 6003 | |  Model 6005 |  Model 6005AH |
| 109-Key Elastomer |  Model 6813 | |  Model 6815 |  Model 6815AA |
| 109-Key Elastomer w/TuffPoint |  Model 6823UN |  Model 6827UN |  Model 6825UN | ✗ Not Available |
| 109-Key Elastomer w/MicroModule |  Model 6833UN |  Model 6837UN |  Model 6835UN | ✗ Not Available |
| 109-Key Elastomer w/MicroJoystick |  Model 6843UN |  Model 6847UN |  Model 6845UN | ✗ Not Available |
| 109-Key Membrane |  Model 6913 | |  Model 6915 |  Model 6915AA |
| 109-Key Membrane w/TuffPoint |  Model 6923UN |  Model 6927UN |  Model 6925UN | ✗ Not Available |
| 109-Key Membrane w/MicroModule |  Model 6933UN |  Model 6937UN |  Model 6935UN | ✗ Not Available |
| 109-Key Membrane w/MicroJoystick |  Model 6943UN |  Model 6947UN |  Model 6945UN | ✗ Not Available |

Items Not to Scale

2. Keyboard Installation

This section of the manual will assist you in installing your D3 keyboard. Read section 2.1 on page 4 for general instructions applicable to all D3 keyboard models. For keyboards with pointing devices, see section 2.2 on page 6 for instructions relating to the pointing device. For mounting instructions and diagrams for panel mount keyboards, see section 2.3, page 8. Mounting instructions and diagrams for keyboard OEM kits can be found in section 2.4 on page 8. Important instructions regarding the installation of intrinsically safe keyboards can be found in section 2.5 on page 8.

2.1. General Instructions

D3 keyboards are directly compatible with all standard PC-style computers. Simply plug the keyboard into the keyboard port (a 6-pin mini-DIN to 5-pin DIN adapter is provided for non-PS/2 keyboard interfaces).

If your keyboard is provided with **sealed connectors**, you must connect your keyboard to the sealed connector receptacle. On enclosures provided by D3, this receptacle should be factory-installed on the enclosure. If you are using your own computer inside of this enclosure, you will have to connect the cable from this receptacle to your computer.

Before installing cable extenders to allow use of the keyboard at some distance from the computer, please keep in mind that the effective limit for keyboard cabling is 20 feet.

If you are using an enclosure that was supplied separately, you will have to install the sealed connector receptacle in the enclosure.

Installing Sealed Keyboard Connector in an Enclosure

Equipment Needed

Drill with bits to make 0.8125" hole in enclosure
Wire stripper
Soldering iron and solder
Adjustable wrench (1" opening)
Cable with correct termination to connect to computer's keyboard port
Sealed keyboard receptacle hardware (obtainable from D3; included with some models) including receptacle, retaining nut, and washer with grounding tab
Wire, 18-24 gauge (3")
Spade or ring terminal
#4-40 screw and KEPS nut
Crimping tool for the spade or ring terminal
Heat shrink (0.125"D and 0.375"D)
Heat gun or similar device to shrink the heat shrink
Multimeter or other continuity tester

Procedure

1. Prepare the keyboard cable by stripping 1" of the jacket from the end opposite the connector that mates with your computer's keyboard port. Leave 0.5" of the cable shield braid exposed.
2. Strip 0.125" from the end of each conductor.
3. Using the signal pinouts in Figure 6-1 on page 25, determine which conductors carry which signals. Cut back any unused conductors at the point from which they exit the cable jacket being careful not to cut or nick any of the used conductors.
4. Tin the used conductors. Twist and tin the cable shield braid.
5. Solder the 3" piece of wire to the cable shield braid. Place a section of the 0.375"D heat shrink long enough to cover any exposed conductor and the soldered junction over this. Shrink the heat shrink over this section.
6. Strip 0.25" from the end of the wire attached to the cable shield braid. Crimp the spade or ring terminal onto this wire.
7. Select a convenient point on your enclosure for the keyboard connector. Drill or punch a 0.8125"D hole at this location. Deburr this hole, paying special attention to ensure that the exterior side of the hole is smooth and flat.

Thread the cable, in the order listed, through the connector retaining nut, the washer with grounding tab, and the mounting hole in the enclosure so that enough of the cable is exposed outside of the enclosure to allow you to solder the connector. See

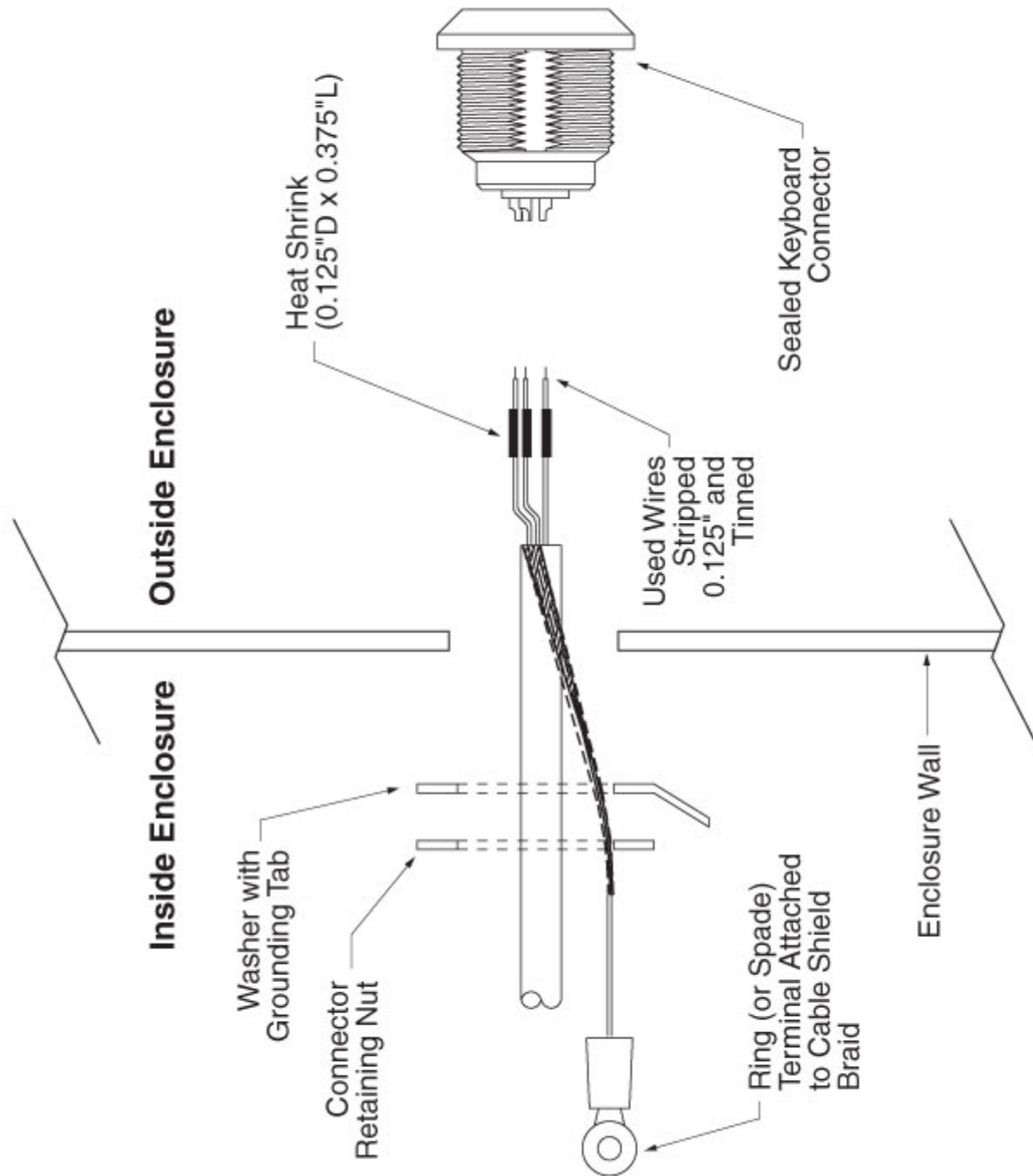

8. Figure 2-1 on page 10 for an illustration.
9. Tin the solder cups on the sealed connector.

10. Place a 0.325" length of the 0.125"D heat shrink over each conductor. Slide this heat shrink as far back the conductor as possible to prevent it from being shrunken by the heat generated during soldering.
11. Use the signal pinout in Figure 6-1 on page 25 to determine which conductor attaches to which terminal on the sealed connector.
12. Solder each connector to the appropriate terminal on the sealed connector being particularly careful to avoid solder bridges between the terminals and cold solder joints. The easiest way to solder these (while preventing the conductor from becoming so hot that it shrinks the heat shrink prematurely) is to heat the solder cup on the connector so that the tinning solder melts, then immediately dip the end of the conductor into the cup, then immediately remove the iron from the cup. When complete, examine the connections to ensure that no solder bridges have inadvertently been formed.
13. Slide the heat shrink down over the soldered junctions on each conductor. Shrink all of the heat shrink being careful to ensure that it does not shrink away from the junction.
14. Pull the cable back into the enclosure so that only an inch or two of the newly terminated end is outside of the enclosure. Feed the ring or spade terminal and wire connected to the cable shield braid back through the enclosure, the washer, and the nut.
15. Draw the cable the remaining distance back into the enclosure along with the shield wire. Seat the sealed connector in its mounting hole being careful to ensure that no wires are pinched between it and the enclosure. Also be careful not to break any of the connections.
16. Turn the sealed connector to the desired orientation. Ensuring that the shield wire and ring terminal are clear of the nut and the washer, screw the nut onto the sealed connector until the connector is drawn as tightly as possible. This ensures that the enclosure is sealed at the mounting point. You should not be able to turn the connector in its hole.
17. Connect the cable shield wire to the grounding tab on the washer with the ring or spade terminal using the #4-40 screw and KEPS nut.
18. Connect the other end of the cable to your computer's keyboard port.

2.2. Pointing Device Instructions

The pointing device installed in D3 keyboard/pointing device combination models typically only needs to be connected to the computer's mouse port to operate. It is compatible with the standard Windows™ mouse drivers (either the Standard Serial Mouse or the Standard PS/2 Mouse driver).

Pointing devices on D3 keyboards are provided with an adapter that allows the pointing device to be used with either a serial or PS/2 interface (**except** for intrinsically safe versions). When the device has standard connectors (that is, non-sealed connectors), this adapter attaches to the end of the pointing device cable from the unit. When the device is supplied with sealed connectors, the adapter is connected to the end of the cable from the sealed receptacle where it attaches to your computer's mouse port. **Note:** intrinsically safe models require different I.S. barrier assemblies for serial and PS/2 pointing devices, so no adapter is supplied; if you require a different pointing device interface, you must contact D3 to obtain a new barrier assembly. When the barriers are integrated in a D3 supplied enclosure, this may require retrofitting your enclosure.

If your keyboard is provided with **sealed connectors**, you must connect your pointing device to the sealed connector receptacle. On enclosures provided by D3, this receptacle should be factory-installed on the enclosure. If you are using your own computer inside of this enclosure, you will have to connect the cable from this receptacle to your computer's mouse port.

Before installing cable extenders to allow installation of the computer at large distances from the pointing device, please keep the following limitations in mind: serial devices generally have a range up to 100 feet; PS/2 devices generally have a range up to 20 feet.

If you are using an enclosure that was supplied separately, you will have to install the sealed connector receptacle in the enclosure.

Installing Sealed Pointing Device Connector in an Enclosure

Equipment Needed

Drill with bits to make 0.8125" hole in enclosure
Wire stripper
Soldering iron and solder
Adjustable wrench (1" opening)
Cable with correct termination to connect to computer's mouse port
Sealed pointing device receptacle hardware (obtainable from D3; included with some models) including receptacle, retaining nut, and washer with grounding tab
Wire, 18-24 gauge (3")
Spade or ring terminal
#4-40 screw and KEPS nut
Crimping tool for the spade or ring terminal
Heat shrink (0.125"D and 0.375"D)
Heat gun or similar device to shrink the heat shrink
Multimeter or other continuity tester

Procedure

1. Prepare the pointing device cable by stripping 1.5" of the jacket from the end opposite the connector that mates with your computer's pointing device port. Leave 0.5" of the cable shield braid exposed.
2. Strip 0.125" from the end of each conductor.
3. Using the signal pinouts in Figure 6-2 on page 26, determine which conductors carry which signals. Ensure that you select the diagram with the correct interface, serial or PS/2. Cut back any unused conductors at the point from which they exit the cable jacket being careful not to cut or nick any of the used conductors.
4. Tin the used conductors. Twist and tin the cable shield braid.
5. Solder the 3" of wire to the cable shield braid. Place a section of the 0.375"D heat shrink long enough to cover any exposed conductor and the soldered junction over this. Shrink the heat shrink over this section.
6. Strip 0.25" from the end of the wire attached to the cable shield braid. Crimp the spade or ring terminal onto this wire.
7. Select a convenient point on your enclosure for the pointing device connector. Drill or punch a 0.8125"D hole at this location. Deburr this hole, paying special attention to ensure that the exterior side of the hole is smooth and flat.
8. Thread the cable, in the order listed, through the connector retaining nut, the washer with grounding tab, and the mounting hole in the enclosure so that enough of the cable is exposed outside of the enclosure to allow you to solder the connector. See Figure 2-2 on page 11 for an illustration.
9. Use the signal pinout in Figure 6-2 on page 26 to determine which conductor attaches to which terminal on the sealed connector. Ensure that you select the diagram with the correct interface, serial or PS/2.
10. Tin the solder cups that will be used on the sealed connector.
11. Place a 0.325" length of the 0.125"D heat shrink over each conductor. Slide this heat shrink as far back the conductor as possible to prevent it from being shrunken by the heat generated during soldering.
12. Solder each connector to the appropriate terminal on the sealed connector being particularly careful to avoid solder bridges between the terminals and cold solder joints. The easiest way to solder these (while preventing the conductor from becoming so hot that it shrinks the heat shrink prematurely) is to heat the solder cup on the connector so that the tinning solder melts, then immediately dip the end of the conductor into the cup, then immediately remove the iron from the cup. When complete, examine the connections to ensure that no solder bridges have inadvertently been formed.
13. Slide the heat shrink down over the soldered junctions on each conductor. Shrink all of the heat shrink being careful to ensure that it does not shrink away from the junction.
14. Pull the cable back into the enclosure so that only an inch or two of the newly terminated end is outside of the enclosure. Feed the ring or spade terminal and wire connected to the cable shield braid back through the enclosure, the washer, and the nut.
15. Draw the cable the remaining distance back into the enclosure along with the shield wire. Seat the sealed connector in its mounting hole being careful to ensure that no wires are pinched between it and the enclosure. Also be careful not to break any of the connections.

16. Turn the sealed connector to the desired orientation. Ensuring that the shield wire and ring terminal are clear of the nut and the washer, screw the nut onto the sealed connector until the connector is drawn as tightly as possible. This ensures that the enclosure is sealed at the mounting point. You should not be able to turn the connector in its hole.
17. Connect the cable shield wire to the grounding tab on the washer with the ring or spade terminal using the #4-40 screw and KEPS nut.
18. Connect the other end of the cable to your computer's mouse port.

2.3. Mounting Instructions for Panel Mounted Keyboards

You must provide a suitable cutout in your equipment panel for your D3 panel mount keyboard. Holes for the mounting hardware are also required. See Table 2-1 below for the figure and page number of the mounting diagram for your model. All required mounting hardware, including nuts and washers, should be included with your keyboard.

| Models Beginning With | Figure Number | Page |
|--|---------------|------|
| 6002, 6005 | Figure 2-3 | 12 |
| 6812, 6815, 6912, 6915 | Figure 2-4 | 13 |
| 6822, 6825, 6922, 6925 | Figure 2-5 | 14 |
| 6832, 6835, 6842, 6845, 6932, 6935, 6942, 6945 | Figure 2-6 | 15 |

Table 2-1 Panel Mount Cutout Illustrations

2.4. Mounting Instructions for Keyboard OEM Kits

When adding a D3 OEM keyboard to your design, it is important that you provide the correct cutout and mounting hardware for correct operation. Diagrams showing the correct cutout and stud pattern for mounting are as follows: 6002AM and 6005AH, see Figure 2-7 on page 16; 6812AA and 6815AA, see Figure 2-8 on page 17; and 6912AA and 6915AA, see Figure 2-8 on page 17. All studs used for mounting the OEM keyboard should be #6-32 studs 0.5" in length. When mounting, use #6-32 lock nuts, always being careful not to pinch cables with the mounting hardware.

2.5. Installing Intrinsically Safe Keyboards

When installing electrical equipment in hazardous areas, it is *exceedingly important* that you are familiar with the National Electrical Code rules, the National Fire Protection Agency regulations, all local codes, and the specifications of your underwriter for hazardous areas. Please be sure that those responsible for installing the equipment are properly qualified for the work and informed of all necessary information and specifications.

IMPORTANT

D3 is not responsible for the installation of your hazardous area equipment. YOU MUST ENSURE THAT THE INSTALLATION OF THIS EQUIPMENT CONFORMS TO ALL APPLICABLE REGULATIONS AND CODES, INCLUDING, BUT NOT LIMITED TO, THOSE OF THE NATIONAL FIRE PROTECTION ASSOCIATION, THE NATIONAL ELECTRICAL CODE, AND ANY APPLICABLE LOCAL CODES. We have included some important information regarding this installation in this manual, but it should not be regarded as the complete set of information required to safely install electrical equipment in hazardous areas. **Always** use a qualified technician to install such equipment.

Intrinsic safety barriers are required in the installation of intrinsically safe keyboards and pointing devices. These barriers are designed to prevent potentially dangerous energy from entering the hazardous area. They must be

connected between the intrinsically safe device and the safe area equipment. The barriers themselves must be located in the safe area. Intrinsic safety barriers are pre-installed in most D3 enclosures and computers for hazardous areas. Stand-alone barrier boxes are available for other applications; these kits include the required cabling and sealed connectors. For your information, drawings of the various barrier arrangements including signal paths are shown in section 6.5 starting on page 28.

Some computers with PS/2 keyboard and pointing device interfaces are very sensitive to the impedance change introduced by the intrinsically safe barriers. Though D3 barrier systems have been designed to work with most PS/2 interfaces, some computers may not operate correctly with the standard configuration. Fortunately, this can be remedied by simply changing one or two resistors in the barrier system. If your PS/2 keyboard or pointing device does not operate through the barrier system, please see section 6.6 on page 34 for suggested modifications. If problems persist, please contact D3's customer service department at 717 932-9999 extension 222.

An industrial PS/2 to USB adapter is recommended for usage with all intrinsically safe barriers, isolators, and current limiting kits.

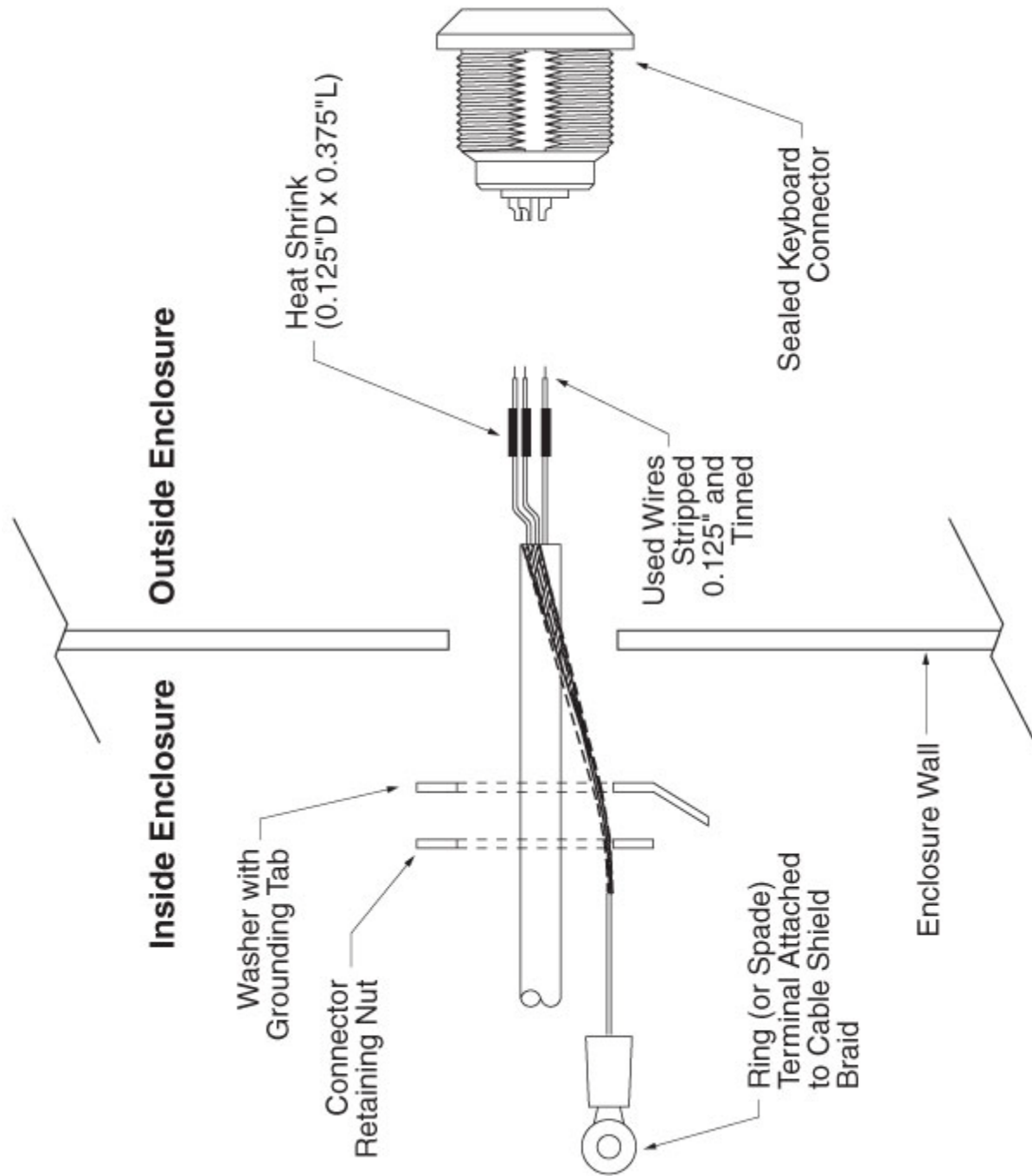

Figure 2-1 Sealed Keyboard Connector Installation
SEE SECTION 6.4 ON PAGE 27 FOR WIRE COLOR CODES
(D3 CABLING ONLY)

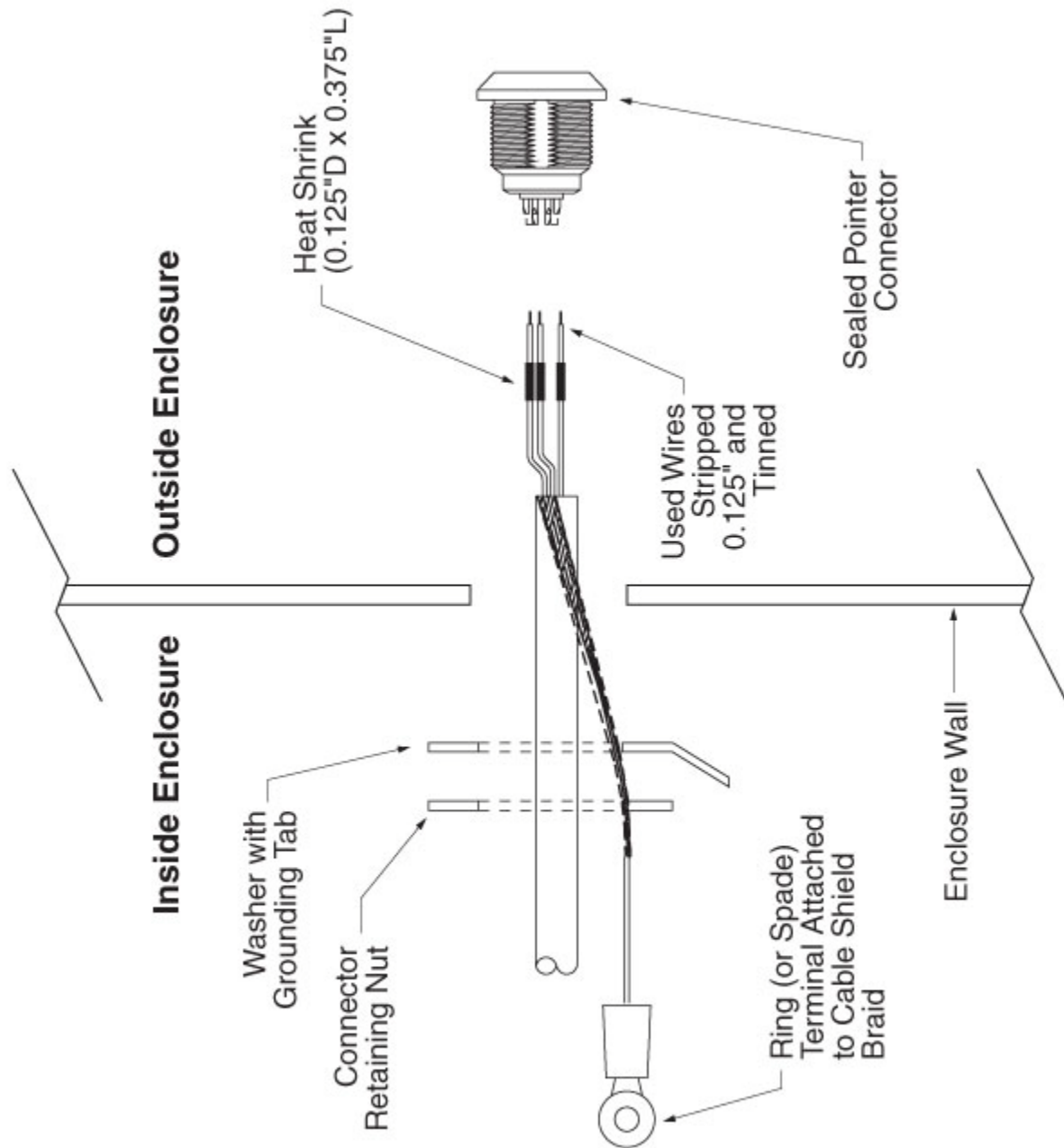

Figure 2-2 Sealed Pointing Device Connector Installation
SEE SECTION 6.4 ON PAGE 27 FOR WIRE COLOR CODES
(D3 CABLING ONLY)

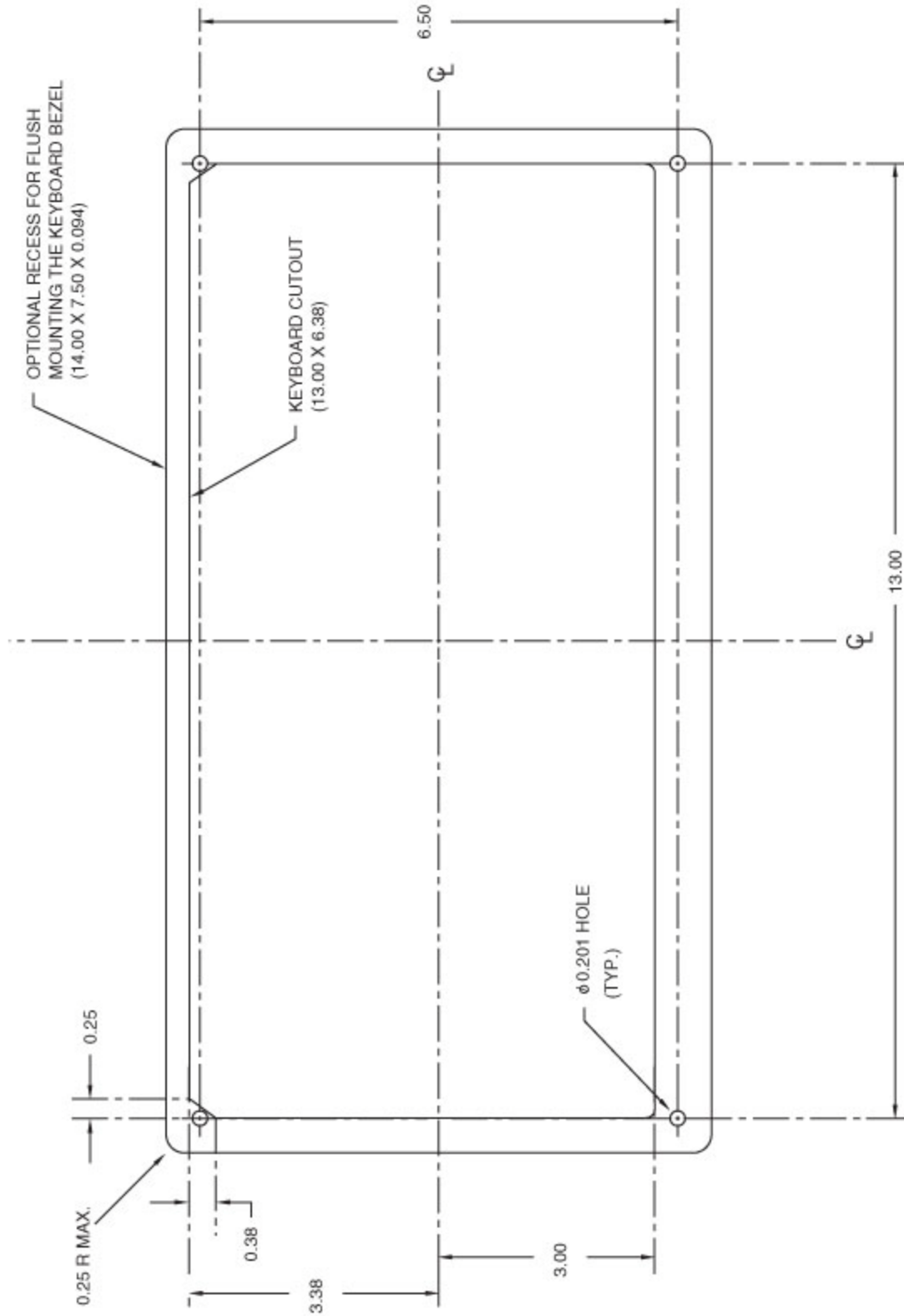

Figure 2-3 Cutout for 6002 / 6005

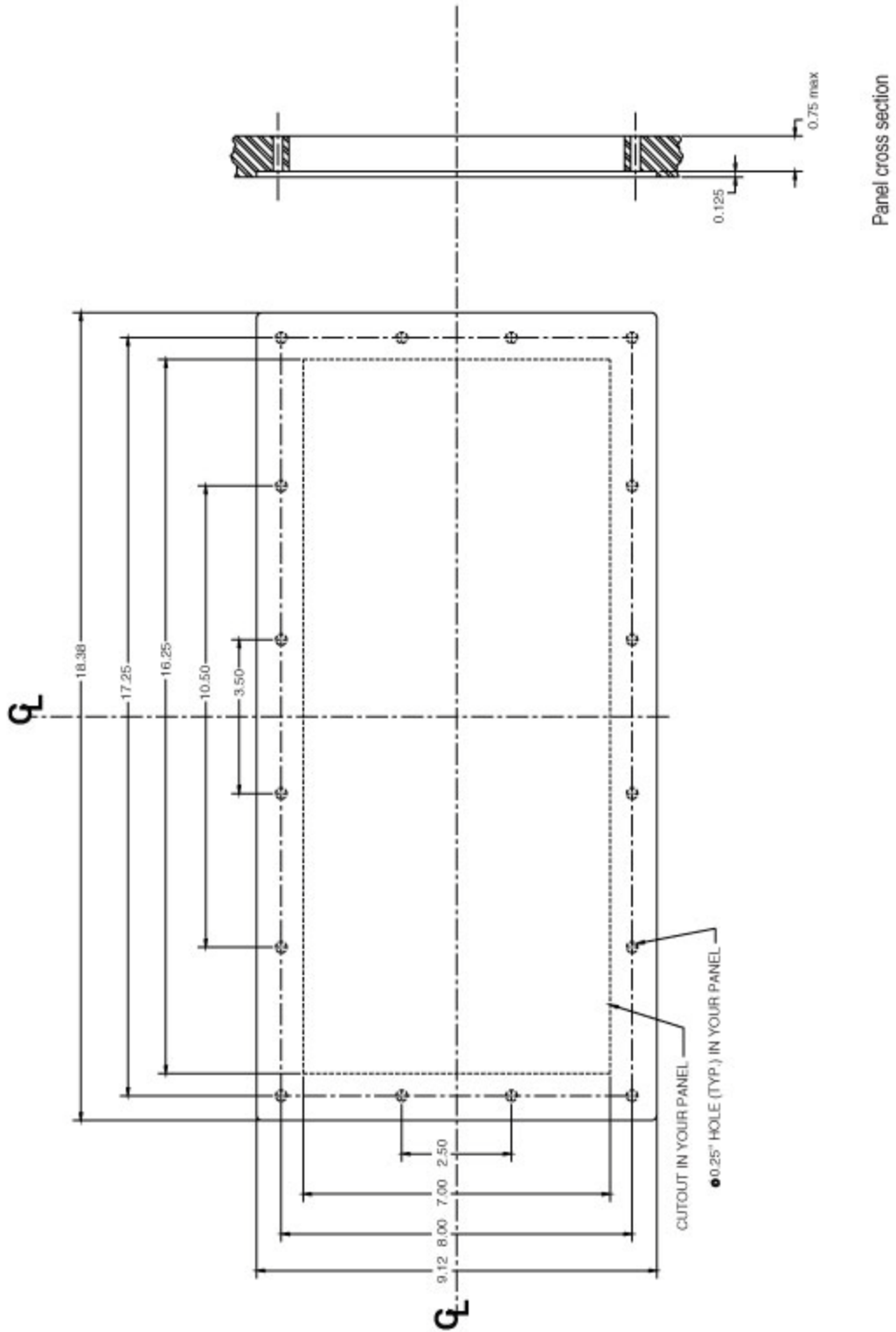

Figure 2-4 Cutout for 6812 / 6815 / 6912 / 6915

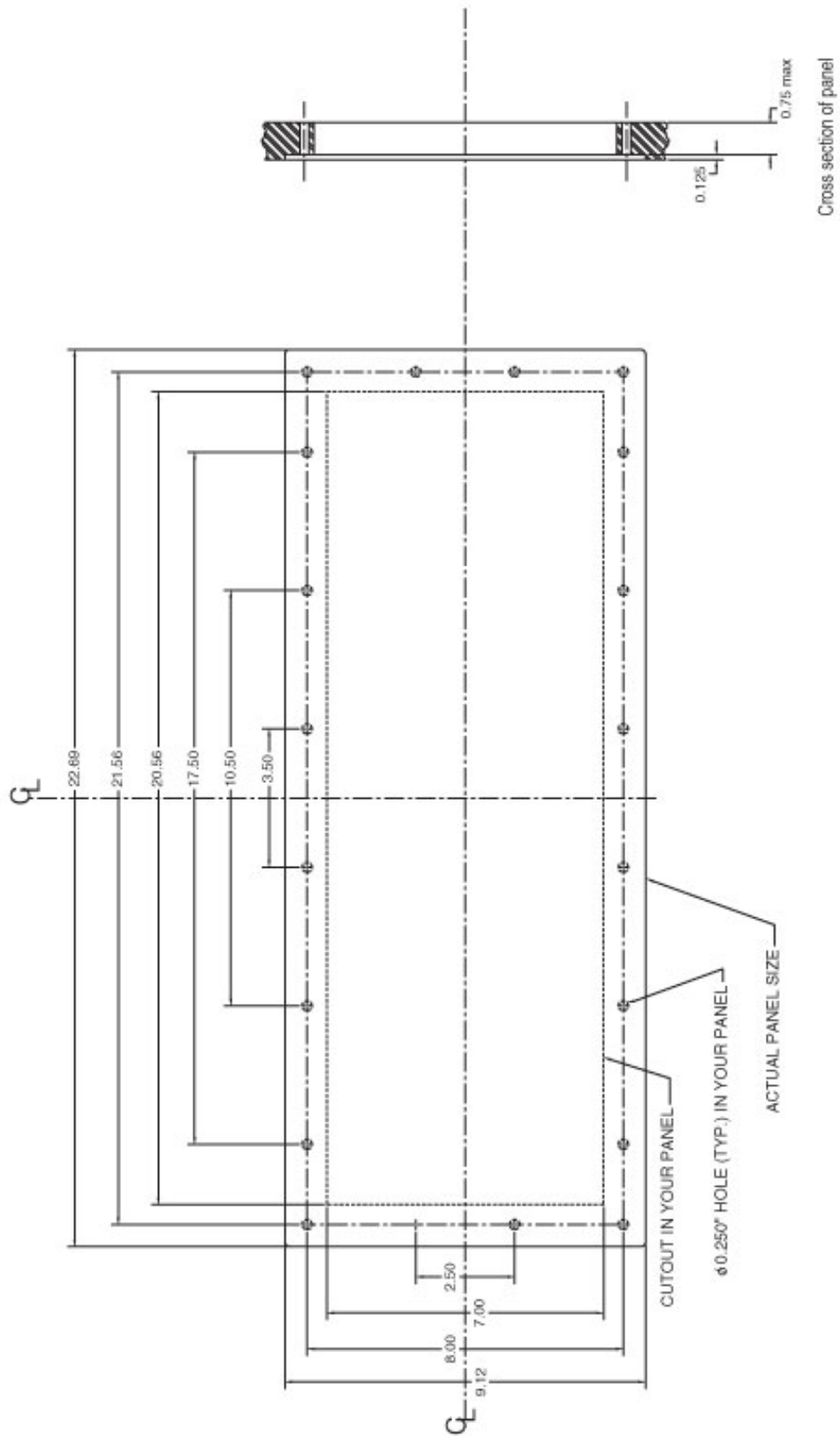

Figure 2-5 Cutout for 6822 / 6825 / 6922 / 6925

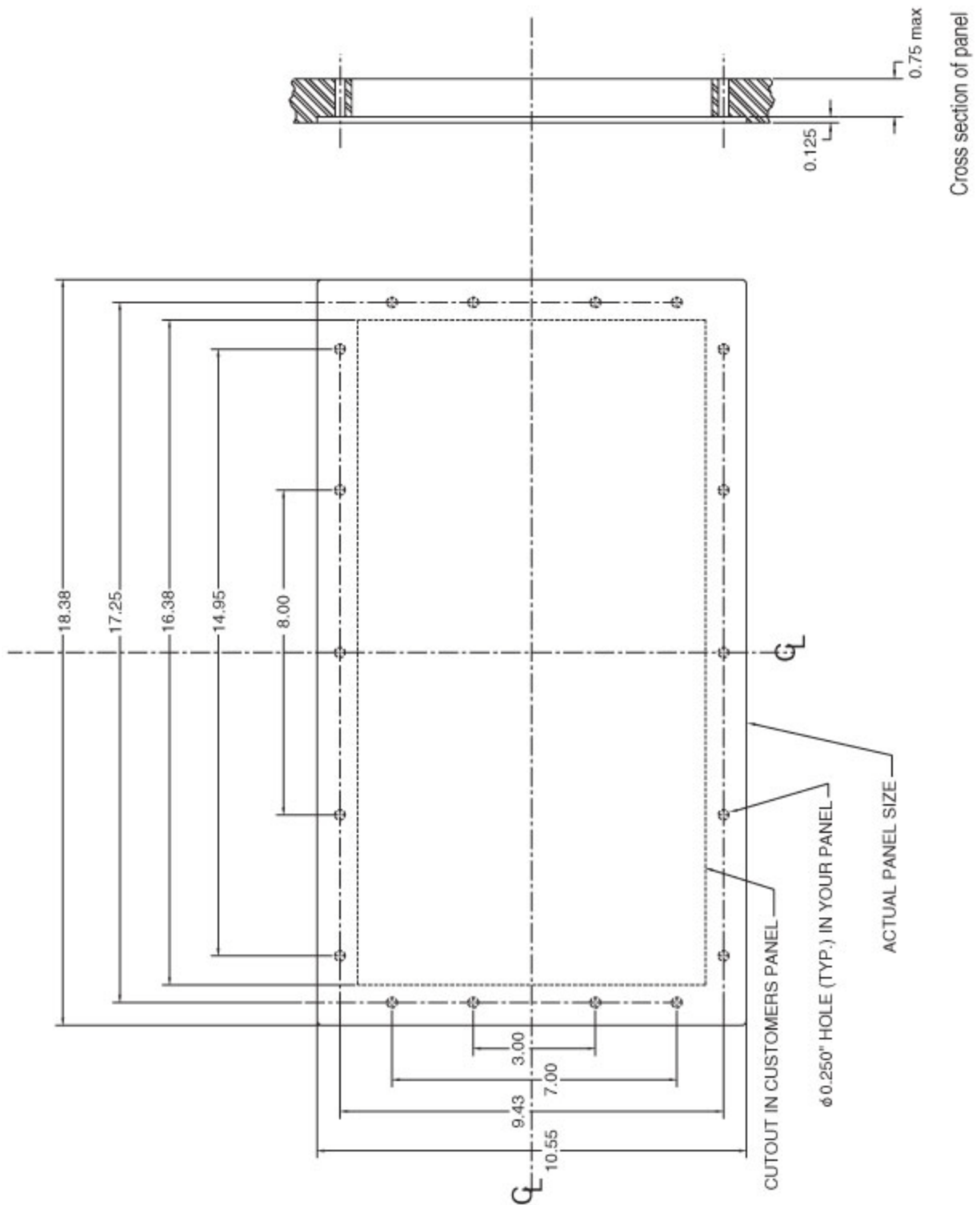

Figure 2-6 Cutout for 6832 / 6835 / 6842 / 6845 / 6932 / 6935 / 6942 / 6945

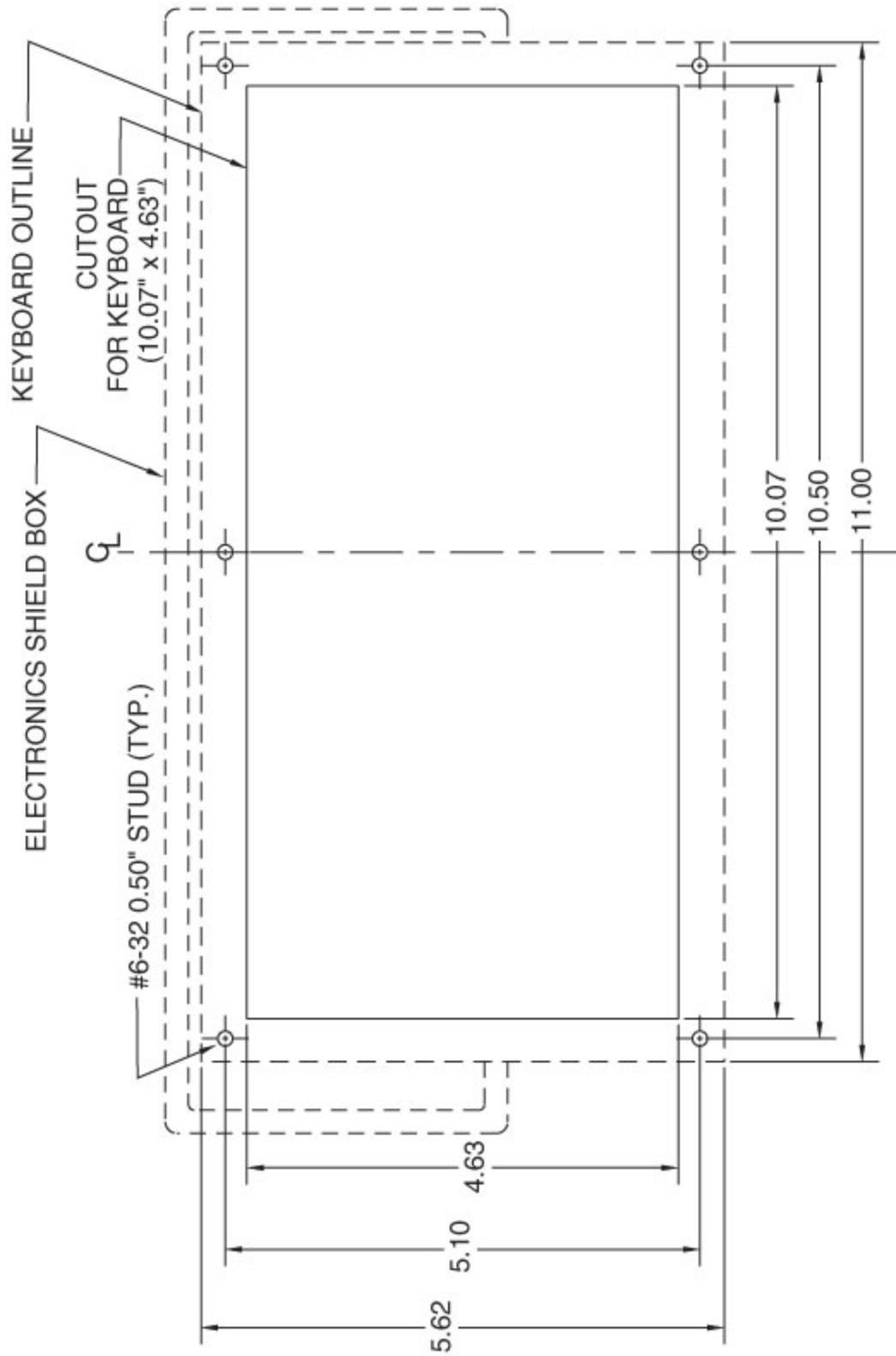

Figure 2-7 Cutout for 6002AM / 6005AH Keyboard OEM Kits

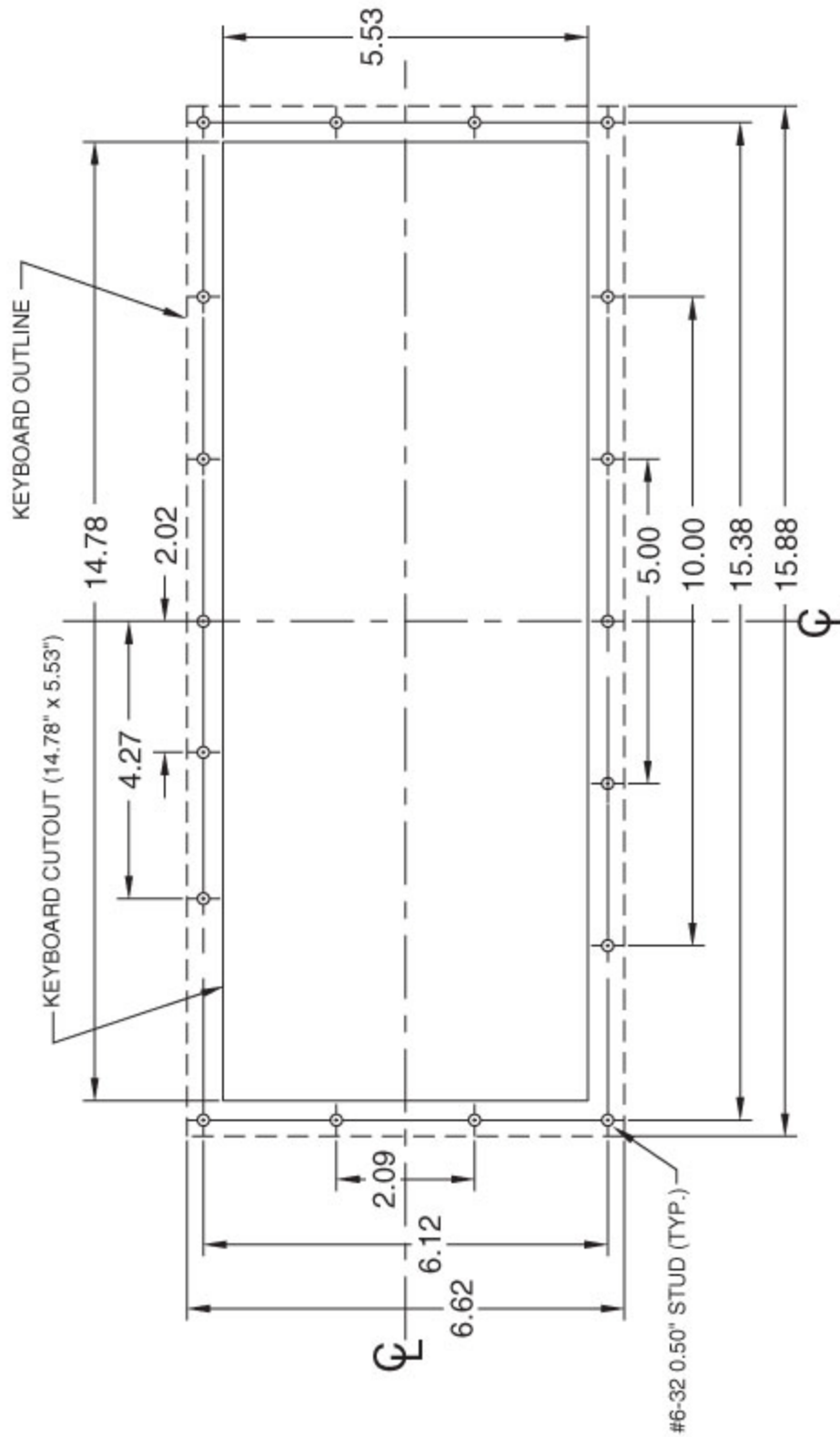

Figure 2-8 Cutout for 6812AA / 6815AA / 6912AA / 6915AA Keyboard OEM Kits

3. Special Notes on D3 60-Key Keyboards

D3's 60-key membrane keyboards are a great choice for custom applications. Because of the keyboard's reduced footprint, it will fit into very compact designs and tight industrial areas in which space is at a premium. These keyboards also provide an extremely affordable solution if you require custom legending and output codes.

3.1. Standard 60-Key Output Codes

| Keyboard Legend | Standard PC Equivalent | Keyboard Legend | Standard PC Equivalent |
|-----------------|------------------------|-----------------|------------------------|
| F1 | [F1] | PAGE AHEAD | [Page Down] |
| F2 | [F2] | PAGE BACK | [Page Up] |
| F3 | [F3] | RESET | [Esc] |
| F4 | [F4] | SPACE | [Spacebar] |
| F5 | [F5] | BACKSPACE | [Backspace] |
| F6 | [F6] | DELETE | [Delete] |
| F7 | [F7] | HOME | [Home] |
| F8 | [F8] | 0 | [0] |
| F9 | [F9] | 1 | [1] |
| F10 | [F10] | 2 | [2] |
| F11 | [Shift]-[F1] | 3 | [3] |
| F12 | [Shift]-[F2] | 4 | [4] |
| F13 | [Shift]-[F3] | 5 | [5] |
| F14 | [Shift]-[F4] | 6 | [6] |
| F15 | [Shift]-[F5] | 7 | [7] |
| F16 | [Shift]-[F6] | 8 | [8] |
| F17 | [Shift]-[F7] | 9 | [9] |
| F18 | [Shift]-[F8] | . | [.] |
| F19 | [Shift]-[F9] | + | [+] |
| F20 | [Shift]-[F10] | - | [-] |
| F21 | [Ctrl]-[F1] | RAISE | [Ctrl]-[F6] |
| F22 | [Ctrl]-[F2] | LOWER | [Ctrl]-[F7] |
| F23 | [Ctrl]-[F3] | ↑ | [↑] |
| F24 | [Ctrl]-[F4] | ← | [←] |
| F25 | [Ctrl]-[F5] | → | [→] |
| ENTER | [Enter] | ↓ | [↓] |

Blank keys do not produce any output from the keyboard.

3.2. Custom Software and Legends

D3's 60-key keyboards can easily be specified with custom software (for output codes), custom legends, or both. The D3 6000 series is unique in this ability in the industrial marketplace, and the charge for customization is unbelievably reasonable.

For customization solutions, contact the D3 sales department at 717 932-9999 or sales@d3inc.net

Another unique feature of the D3 6000 series is that you can change the legend yourself in the field. The instructions below will help you change legends if you have a need to do so.

3.3. Changing Legends on the 60-Key Membrane Keyboard

1. If the keyboard is a desktop unit, remove the back of the keyboard enclosure, being careful to retain all of the screws and washers for reassembly.
2. If the keyboard is a rack or panel mount unit, remove the aluminum box covering the keyboard electronics, being careful to retain all of the screws and washers for reassembly.

3. Remove the printed circuit board from the back of the keyboard by removing the 6 standoffs (or screws). Ensure that you do not accidentally disconnect the keyboard cable from the printed circuit board. Also be careful to retain the standoffs (screws on desktop units) and washers for reassembly.
4. Remove the keyboard from its enclosure or panel, being careful to retain all of the nuts for reassembly.
5. The legends are long strips of printed material. The ends of these strips extend out of the top of the keyboard. Gently and slowly pull on the exposed tabs to remove the legends. You can use these legends as a template to create your custom legend. Note that stiffer material is better for the legends, as it is easier to insert in the keyboard.
6. When you have prepared your new legends (taking particular care that the strip widths are the same as the original legends), carefully insert your new legends in place of the old ones.
7. Replace the keyboard in the enclosure or panel. Using the original nuts, tighten to 5 inch-pounds.
8. Replace the printed circuit board, being careful not to disconnect the keyboard cable. Affix in place using the original inner-tooth lock washers and standoffs (screws on desktop units). BE VERY CAREFUL not to overtighten the standoffs, as the threads will strip if tightened excessively.
9. If the keyboard is a rack or panel mount unit, replace the aluminum box over the keyboard electronics. It is easiest to start each of the six screws first, to bring the standoffs into alignment with the box's holes. Do not forget to use the inner-tooth lock washers. BE VERY CAREFUL not to overtighten these screws, as the threads in the standoffs are subject to stripping at high torques.
10. If the keyboard is a desktop unit, replace the back of the keyboard enclosure. Use the original screws and split washers to affix the back. NOTE: if a screw starts to bind before it is fully inserted, immediately remove the screw and clean its threads. The gasketing on the keyboard can get caught in the screw's threads, causing them to bind - if a screw is forced in these circumstances, cross threading, stripping, or screw shearing may result.

4. Recommended Computer Peripheral Ergonomics Guide

Ergonomics, the science of human comfort and health in relation to the work environment and its tools, is not a new field of study. The word has been used to describe this “human engineering” since long before computers were in common use. However, the proliferation of computers and their keyboards and pointing devices has brought a new level of importance to the careful consideration of ergonomics in designing a safe, healthy, and comfortable workplace.

In this section, we present some tips and ideas that may help you to provide a more comfortable workspace and reduce fatigue and strain associated with using your computer. Of course, every individual will have different needs, so remember to use your own judgment and comfort as a guide in good workspace design and good work habits.

Workspace

When it is possible you should arrange your workspace into three “zones.” These zones are based on how frequently you need access to the items in the zone.

- Inner Zone – the closest zone to you, within the distance from your elbow to the end of your hand. Place items that you use all of the time in this zone (keyboard, mouse, etc.)
- Middle Zone – within arm’s reach. Items that you use often, but don’t need all of the time (such as pens and notepad), should be placed in this zone.
- Outer Zone – outside of reach. Items that you rarely need should be placed in this zone.

These zones are only guideline. You should take particular care not to crowd your inner and middle zones in an attempt to ensure easy access, as this will lead to other problems.

If you frequently need to refer to a document while working on the computer, you should use a document holder (or “copy board”) to hold it in a convenient viewing position that minimizes the amount of head turning required to refer to it. A document holder should be at the same distance from your eyes as the monitor to reduce eyestrain cause by refocusing your eyes.

Posture

If you are working at you computer for extended periods of time, it is important that you maintain good posture. The placement of your equipment and the adjustment of chair, desk (or keyboard shelf), and monitor can assist you in this.

- Your monitor should be placed at eye level
- Adjust your chair back so that it is in contact with your back while you are working
- If you have armrests, they should be adjusted to a height that allows your elbows to rest on them without hunching over
- Your keyboard should be just below the level of your elbows when you are in a relaxed but not slouching position to type
- Your feet should be able to rest flat on the ground or on a footrest if you work at your computer seated

Of course, you must also work with your tools in such a way as to keep good posture – the items in your workspace cannot do all of the work by themselves!

- Work in a relaxed position, neither slouching nor shrugging to stay in correct position
- Your hands should be positioned above the keyboard with your fingers slightly curled – do not rest your wrists on the working surface while typing, only use the wrist rest during periods between typing
- Don’t rest your wrists on the hard edge of the work surface; instead, use a wrist rest
- Don’t allow the backs of your knees to press against the edge of your chair

- Adjust your position throughout the day and alternate tasks to allow yourself to recover from each task and reduce fatigue

Vision Health

It is important to use techniques to prevent eye strain while working on a computer. Computer monitors can be very tiring to the eyes if used continuously or improperly.

- Keep your monitor's screen clean
- Adjust monitor height so that the top of the monitor is at eye level
- Keep the monitor level or tilted slightly down to prevent glare from ceiling mounted light fixtures
- Position the monitor (or yourself) so that the screen is 18" to 24" from your eyes
- Position the monitor so that sources of glare or distracting reflections (such as windows, bright light sources, light objects on dark backgrounds, etc.) are not reflected into your eyes on the monitor screen

Good Habits and Good Health

Try to remember to keep up your good practices at all times. When you catch yourself slipping, just start over again. This will help you to develop good work habits.

General physical health also helps to reduce the risk of body strain and will increase your comfort level. Eat healthily, exercise, and get plenty of rest.

The following are particularly important habits to develop to work more comfortably and protect yourself from injuries associated with long-term use of computers and computer peripherals.

- When using keyboards and pointing devices, ensure that they are positioned at a level just below your fingertips when you are standing relaxed (yet not slumped) with your arms bent 90° at the elbows
- Keep your wrists straight and your fingers slightly curved while typing or using your pointing device
- Use a light touch on your keyboard and mouse – don't overexert or use more muscle power than is needed
- If you need to perform awkward tasks or tasks requiring exertion repetitively, take frequent short breaks and alternate tasks as much as possible
- Avoid working in any positions that requires awkward bending, twisting, reaching, or exertion

5. Maintenance and Cleaning

While D3's products are designed to be durable and dependable, certain parts need to be maintained, and cleaned occasionally. This will help to keep units operating at full potential.

Periodically inspect keyboards and mouse surfaces for visible damage. Cuts, cracks, and abrasions may allow water to enter, causing corrosion or short circuiting. Also inspect cables for wear and damage. Damage to the cable sheath may lead to short circuiting.

In order to clean the Elastomer, Tuffpoint, MicroJoystick, and MicroModule, use mild soap and lightly scrub with a soft brush. Remove any buildup of dirt around the buttons on the Tuffpoint, MicroJoystick, and MicroModule. Use the vinyl dust cover on the Elastomer, MicroJoystick, and MicroModule.

Avoid using any abrasive cleaning products on the Membranes. Also avoid using live steam for cleaning purposes.

Cleaning the Trackball Cup:

Tool Requirement (Including but not limited to the following)

Small Allen or Hex Key Wrench Set

Mild Cleaner

Needle Nose Pliers

Power Notice

Some systems can have power and active signals from multiple sources. Please make sure all power and signal sources are de-energized before proceeding.

Procedure

1. Remove the three stainless steel button head screws that holds the stainless trim ring around the trackball.
2. Remove the trim ring.
3. Unscrew the face ring from the trackball.
4. Clean the cup with a mild cleaner.
5. Replace the face ring.
6. Replace the trim ring and secure with screws removed in step 1.

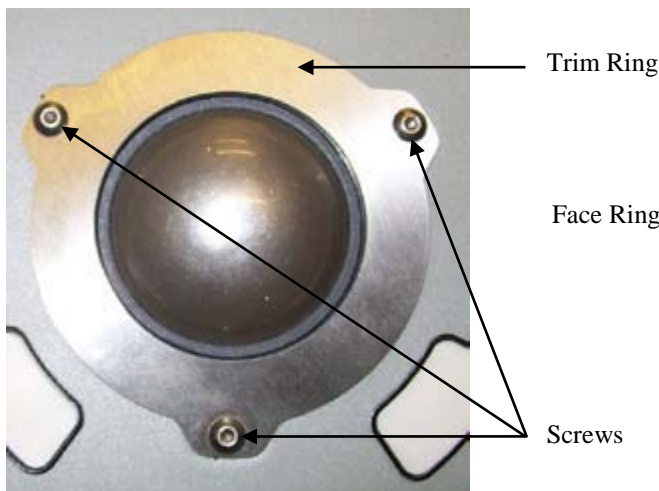

Figure 5-1 Sealed Trackball

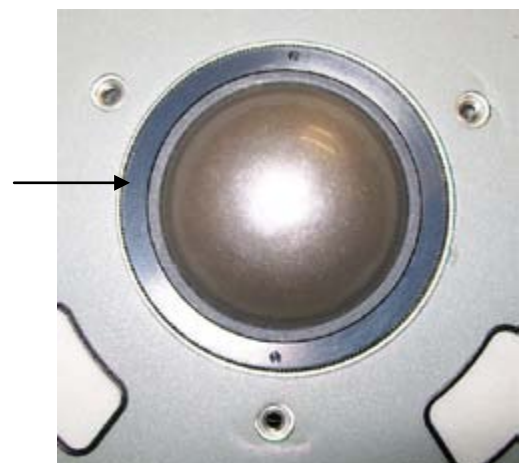

Figure 5-2 Trackball Face Ring

6. Appendices

6.1. Appendix A - Keyboard Specifications

Materials

| | |
|---|----------------------------------|
| Enclosure (desktop units): | 304 Stainless Steel, #4 Finish |
| Panel (rack and panel mount units): | 304 Stainless Steel, #4 Finish |
| Electronics RF Shield (rack/panel mount and OEM units): | Brushed Aluminum |
| Keyboard (Membrane units): | Hard-coat polycarbonate |
| Keyboard (Elastomer units): | Silicon-based elastomeric rubber |
| Pointing Device (units with included pointing device): | Silicon-based elastomeric rubber |

Dimensional

| Models | Height (inches) | Width (inches) | Depth (inches) | Weight (lbs.) |
|---|-------------------------------|---------------------------------|----------------|---------------|
| 6000 / 6003 | 1.50 | 12.00 | 6.50 | 4 |
| 6002 / 6005 | 1.50 | 14.00 | 7.50 | 3 |
| 6810 / 6813 / 6910 / 6913 | 2.40 | 17.20 | 8.20 | 8 |
| 6812 / 6815 / 6912 / 6915 | 9.13 | 18.38 | 1.56 | 5 |
| 6820 / 6823 / 6920 / 6923 6830 / 6833 / 6930 / 6933 6840 / 6843 / 6940 / 6943 | 2.40 | 21.40 | 8.20 | 10 |
| 6822 / 6825 / 6922 / 6925 | 1.56 | 22.70 | 9.13 | 8 |
| 6832 / 6835 / 6932 / 6935 6842 / 6845 / 6942 / 6945 | 1.50 | 18.00 | 10.55 | 8 |
| 6950 | 2.50 | 17.19 | 8.12 | 7 |
| 6002AM / 6005AH (OEM Kits) | 6.00 (Total) 4.63 (Cutout) | 12.22 (Total) 10.07 (Cutout) | 1.53 | 2 |
| 6812AA / 6815AA (OEM Kits) | 6.62 (Total) 5.53 (Cutout) | 15.88 (Total) 14.78 (Cutout) | 1.65 | 2 |
| 6912AA / 6915AA (OEM Kits) | 6.62 (Total) 5.53 (Cutout) | 15.88 (Total) 14.78 (Cutout) | 1.58 | 2 |

Environmental

| | |
|---------------------------------|------------------|
| Operating Temperature: | 0 – 55° C |
| Storage Temperature: | 0 – 70° C |
| Relative Humidity: | 10% - 100% |
| Enclosure Design (desktop): | NEMA 4X, NEMA 13 |
| Front Panel (rack/panel mount): | NEMA 4X, NEMA 13 |

Electrical

| | |
|----------------------------|--------------------------------------|
| NEMA 4X Models: | 5VDC @ 200mA (from keyboard port) |
| Intrinsically Safe Models: | 5VDC @ 15mA max (from keyboard port) |

| | |
|---------------------------|---------------------------------|
| Pointing Device, NEMA 4X: | 5VDC @ 20mA (from PS/2 port) |
| | 12VDC @ 20mA (from serial port) |

| | |
|--------------------------------------|-------------------------------------|
| Pointing Device, Intrinsically Safe: | 5VDC @ 15mA max (from PS/2 port) |
| | 12VDC @ 15mA max (from serial port) |

General

| | |
|-------|--|
| MTBF: | 2 million keystrokes (60-key membrane) |
| | 2 million keystrokes (109-key elastomer) |
| | 3 million keystrokes (109-key membrane) |

Cable Connections Provided:

- 6-pin Mini-DIN (non-sealed NEMA 4X keyboard) with 5-pin DIN adapter
- 9-pin D (non-sealed NEMA 4X pointing device) with 6-pin Mini-DIN adapter
- 5-pin NEMA 4X sealed connector (keyboard on I.S. models, optional other models)
- 10-pin NEMA 4X sealed connector (pointing device on I.S. models, optional other models)

| | |
|---------------|--|
| Cable Length: | 5 feet (desktop and drawer mount units) |
| | 6 feet (rack mount, panel mount, and OEM kits) |

6.2. Appendix B – Connector Pinouts for Keyboards

5-Pin DIN Plug

| <u>Signal</u> | <u>Pin</u> |
|----------------|------------|
| Clock | 1 |
| Data | 2 |
| Reset (unused) | 3 |
| Ground | 4 |
| +5 | 5 |
| Shield | Shell |

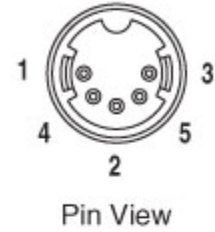

6-Pin Miniature DIN Plug (for PS/2 interfaces)

| <u>Signal</u> | <u>Pin</u> |
|---------------|------------|
| Data | 1 |
| Unused | 2 |
| Ground | 3 |
| +5 | 4 |
| Clock | 5 |
| Unused | 6 |
| Shield | Shell |

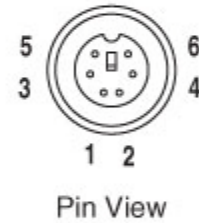

5-Pin NEMA 4X Sealed Plug

| <u>Signal</u> | <u>Pin</u> |
|----------------|------------|
| Clock | 1 |
| Data | 2 |
| Reset (unused) | 3 |
| Ground | 4 |
| +5 | 5 |
| Shield | Shell |

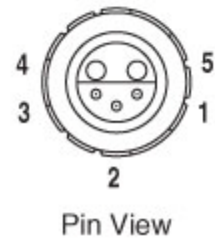

Figure 6-1 Keyboard Connector Pinouts

6.3. Appendix C – Connector Pinouts for Pointing Devices











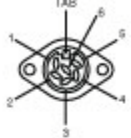
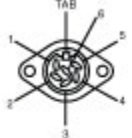

| PS/2 Connectors | Serial Connectors |
|--|---|
| <p style="text-align: center;">POINTER CONNECTOR A: 6 PIN DIN PLUG</p>  <p style="font-size: small;">PIN 1 - DATA PIN 2 - NO CONNECTION PIN 3 - GROUND PIN 4 - +5 VOLTS PIN 5 - CLOCK PIN 6 - NO CONNECTION</p> | <p style="text-align: center;">POINTER CONNECTOR A: 6 PIN DIN PLUG</p>  <p style="font-size: small;">PIN 1 - RTS PIN 2 - RXD PIN 3 - TXD PIN 4 - DTR PIN 5 - GROUND PIN 6 - NO CONNECTION</p> |
| <p style="text-align: center;">POINTER CONNECTOR E: 6 PIN DIN RECEPTACLE</p>  <p style="font-size: small;">PIN 1 - DATA PIN 2 - NO CONNECTION PIN 3 - GROUND PIN 4 - +5 VOLTS PIN 5 - CLOCK PIN 6 - NO CONNECTION</p> | <p style="text-align: center;">POINTER CONNECTOR E: 6 PIN DIN RECEPTACLE</p>  <p style="font-size: small;">PIN 1 - RTS PIN 2 - RXD PIN 3 - TXD PIN 4 - DTR PIN 5 - SIGNAL GROUND PIN 6 - NO CONNECTION</p> |
| <p style="text-align: center;">POINTER CONNECTOR C: 6 PIN MINI DIN PLUG</p>  <p style="font-size: small;">PIN 1 - DATA PIN 2 - NO CONNECTION PIN 3 - GROUND PIN 4 - +5 VOLTS PIN 5 - CLOCK PIN 6 - NO CONNECTION</p> | <p style="text-align: center;">POINTER CONNECTOR C: DB9 RECEPTACLE</p>  <p style="font-size: small;">PIN 1 - NO CONNECTION PIN 2 - RXD PIN 3 - TXD PIN 4 - DTR PIN 5 - SIGNAL GROUND PIN 6 - NO CONNECTION PIN 7 - RTS PIN 8 - NO CONNECTION PIN 9 - NO CONNECTION</p> |
| <p style="text-align: center;">POINTER CONNECTOR F: 6 PIN MINI DIN RECEPTACLE</p>  <p style="font-size: small;">PIN 1 - DATA PIN 2 - NO CONNECTION PIN 3 - GROUND PIN 4 - +5 VOLTS PIN 5 - CLOCK PIN 6 - NO CONNECTION</p> | <p style="text-align: center;">POINTER CONNECTOR C: DB9 PLUG</p>  <p style="font-size: small;">PIN 1 - NO CONNECTION PIN 2 - RXD PIN 3 - TXD PIN 4 - DTR PIN 5 - SIGNAL GROUND PIN 6 - NO CONNECTION PIN 7 - RTS PIN 8 - NO CONNECTION PIN 9 - NO CONNECTION</p> |
| <p style="text-align: center;">POINTER CONNECTOR G: 10 PIN LEMO PLUG</p>  <p style="font-size: small;">PIN 1 - CLOCK PIN 2 - NO CONNECTION PIN 3 - NO CONNECTION PIN 4 - NO CONNECTION PIN 5 - SIGNAL GROUND PIN 6 - NO CONNECTION PIN 7 - NO CONNECTION PIN 8 - +5 VOLTS PIN 9 - DATA</p> | <p style="text-align: center;">POINTER CONNECTOR G: 10 PIN LEMO PLUG</p>  <p style="font-size: small;">PIN 1 - NO CONNECTION PIN 2 - RXD PIN 3 - TXD PIN 4 - DTR PIN 5 - SIGNAL GROUND PIN 6 - NO CONNECTION PIN 7 - RTS PIN 8 - NO CONNECTION PIN 9 - NO CONNECTION</p> |
| <p style="text-align: center;">POINTER CONNECTOR H: 10 PIN LEMO RECEPTACLE</p>  <p style="font-size: small;">PIN 1 - CLOCK PIN 2 - NO CONNECTION PIN 3 - NO CONNECTION PIN 4 - NO CONNECTION PIN 5 - SIGNAL GROUND PIN 6 - NO CONNECTION PIN 7 - NO CONNECTION PIN 8 - +5 VOLTS PIN 9 - DATA</p> | <p style="text-align: center;">POINTER CONNECTOR H: 10 PIN LEMO RECEPTACLE</p>  <p style="font-size: small;">PIN 1 - NO CONNECTION PIN 2 - RXD PIN 3 - TXD PIN 4 - DTR PIN 5 - SIGNAL GROUND PIN 6 - NO CONNECTION PIN 7 - RTS PIN 8 - NO CONNECTION PIN 9 - NO CONNECTION</p> |
| <p style="text-align: center;">POINTER CONNECTOR I: DB9 RECEPTACLE</p>  <p style="font-size: small;">PIN 1 - CLOCK PIN 2 - NO CONNECTION PIN 3 - NO CONNECTION PIN 4 - NO CONNECTION PIN 5 - SIGNAL GROUND PIN 6 - NO CONNECTION PIN 7 - NO CONNECTION PIN 8 - +5 VOLTS PIN 9 - DATA</p> | <p style="text-align: center;">POINTER CONNECTOR F: 6 PIN MINI DIN RECEPTACLE</p>  <p style="font-size: small;">PIN 1 - RTS PIN 2 - RXD PIN 3 - TXD PIN 4 - DTR PIN 5 - SIGNAL GROUND PIN 6 - NO CONNECTION</p> |

Figure 6-2 Pointing Device Connector Pinouts

6.4. Appendix D – D3 Cable Wire Color Codes

Please note that these color codes only apply to cabling provided by D3. Other manufacturer’s cables may have different color codes. See sections 6.2 and 6.3 on pages 25 and 26 for connector pinouts.

Keyboard Cables & Connectors

| Signal | Color | 5-Pin DIN | 6-Pin MiniDIN | 5-Pin Sealed | 6-position MTA |
|---------------|-------|-----------|---------------|--------------|----------------|
| Clock | Brown | 1 | 5 | 1 | 4 |
| Data | Black | 2 | 1 | 2 | 3 |
| No Connection | | 3 | 2, 6 | 3 | 2, 6 |
| Signal Ground | White | 4 | 3 | 4 | 5 |
| +5 VDC | Green | 5 | 4 | 5 | 1 |

Serial Pointing Device Cables & Connectors

| Signal | Color | DB9 | 10-Pin Sealed | 10-position DR |
|---------------|--------|------------|----------------|----------------|
| RXD | Brown | 2 | 2 | 4 |
| TXD | Red | 3 | 3 | 3 |
| DTR | Orange | 4 | 4 | 2 |
| RTS | Blue | 7 | 7 | 9 |
| Signal Ground | Yellow | 5 | 5 | 1 |
| No Connection | | 1, 6, 8, 9 | 1, 6, 8, 9, 10 | 5, 6, 7, 8, 10 |

PS/2 Point Device Cables & Connectors

| Signal | Color | 6-Pin MiniDIN | DB9 | 10-Pin Sealed |
|---------------|--------|---------------|---------------|-------------------|
| Clock | Black | 5 | 1 | 1 |
| Data | White | 1 | 9 | 9 |
| Signal Ground | Yellow | 3 | 5 | 5 |
| +5 VDC | Violet | 4 | 8 | 8 |
| No Connection | | 2, 6 | 2, 3, 4, 6, 7 | 2, 3, 4, 6, 7, 10 |

6.5. Appendix E – Barrier Assembly Drawings

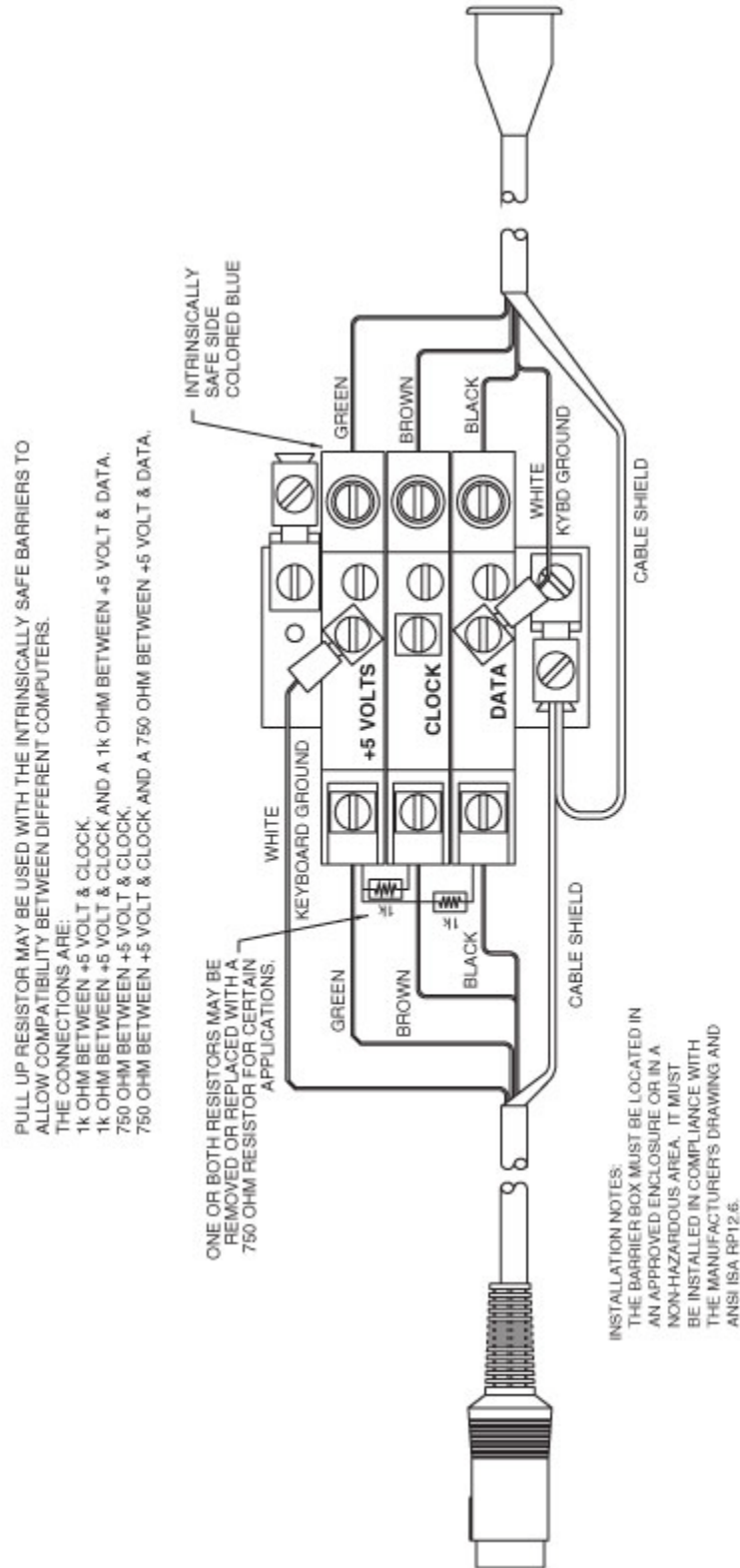

Figure 6-3 I.S. Keyboard Barriers in Barrier Kit Assembly

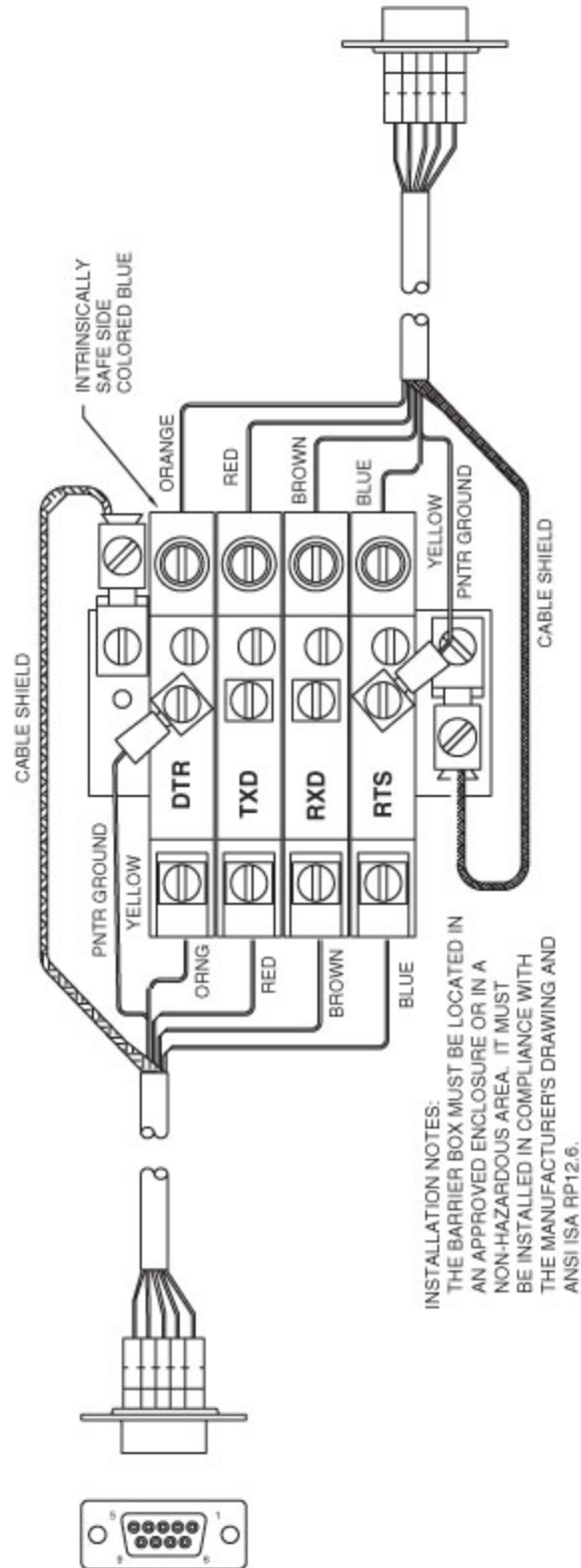

Figure 6-4 I.S. Pointer Barriers (Serial) in Barrier Kit Assembly

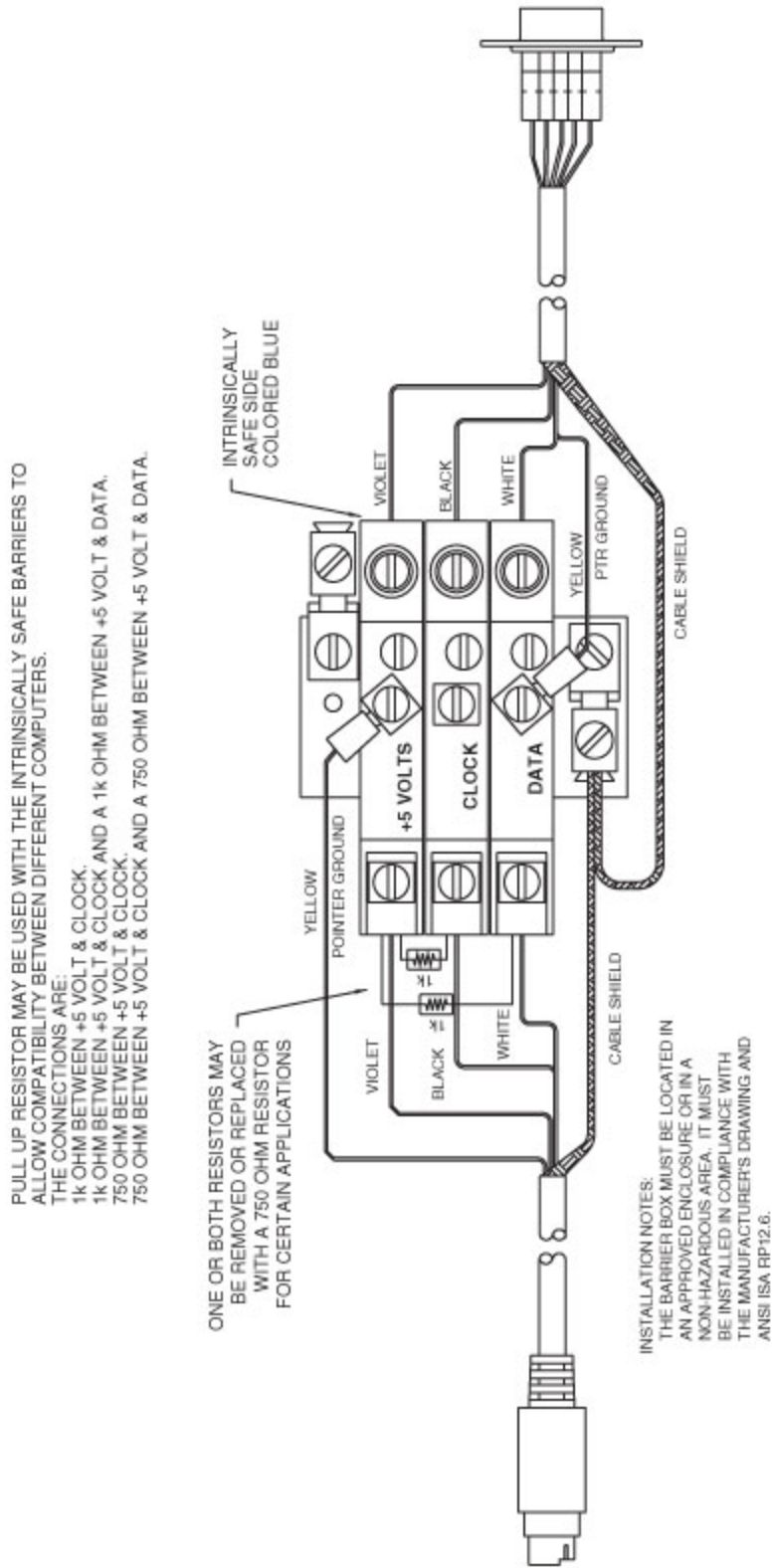

Figure 6-5 I.S. Pointer Barriers (PS/2) in Barrier Kit Assembly

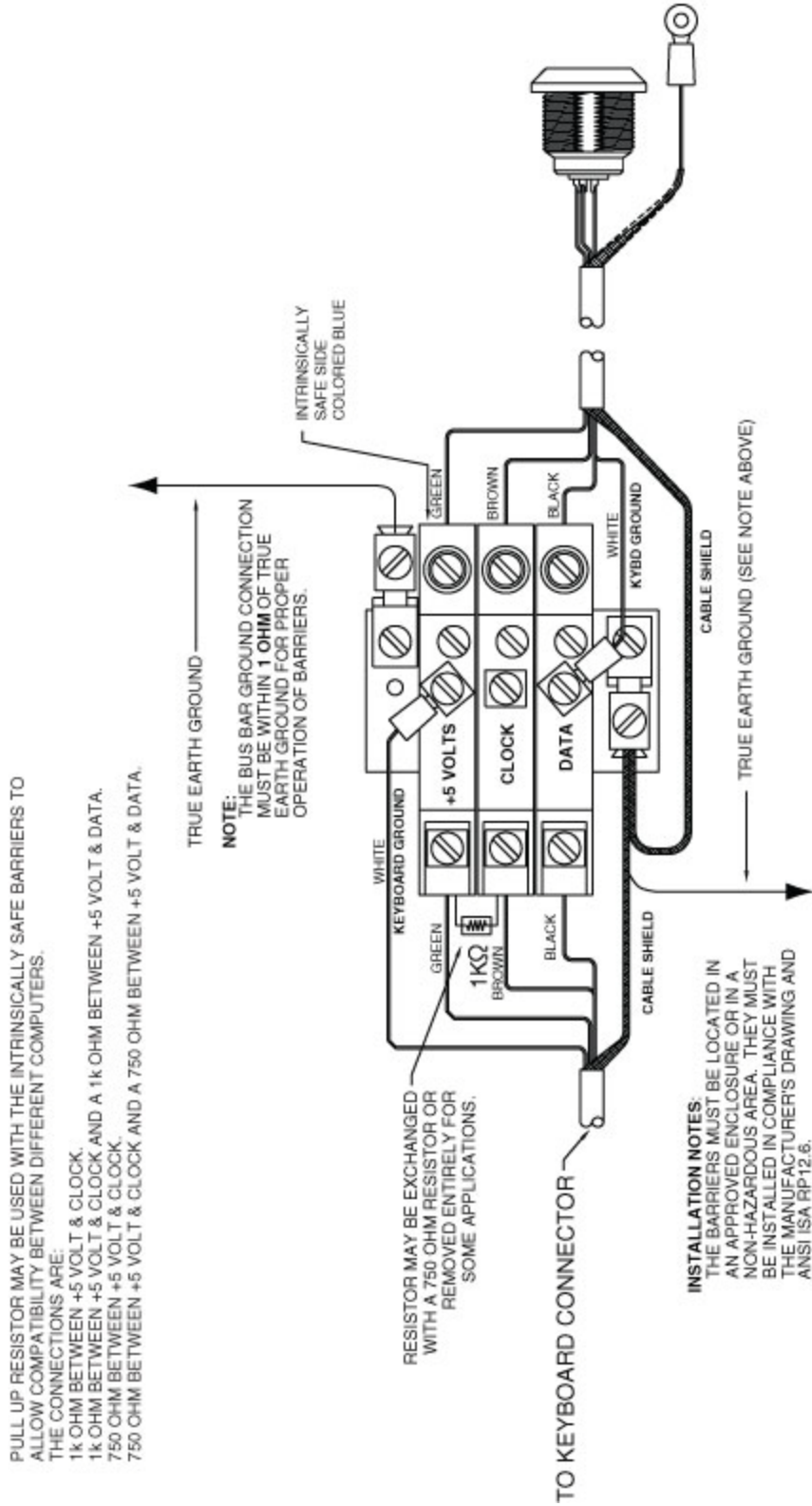

Figure 6-6 I.S. Keyboard Barriers Installed in Enclosure

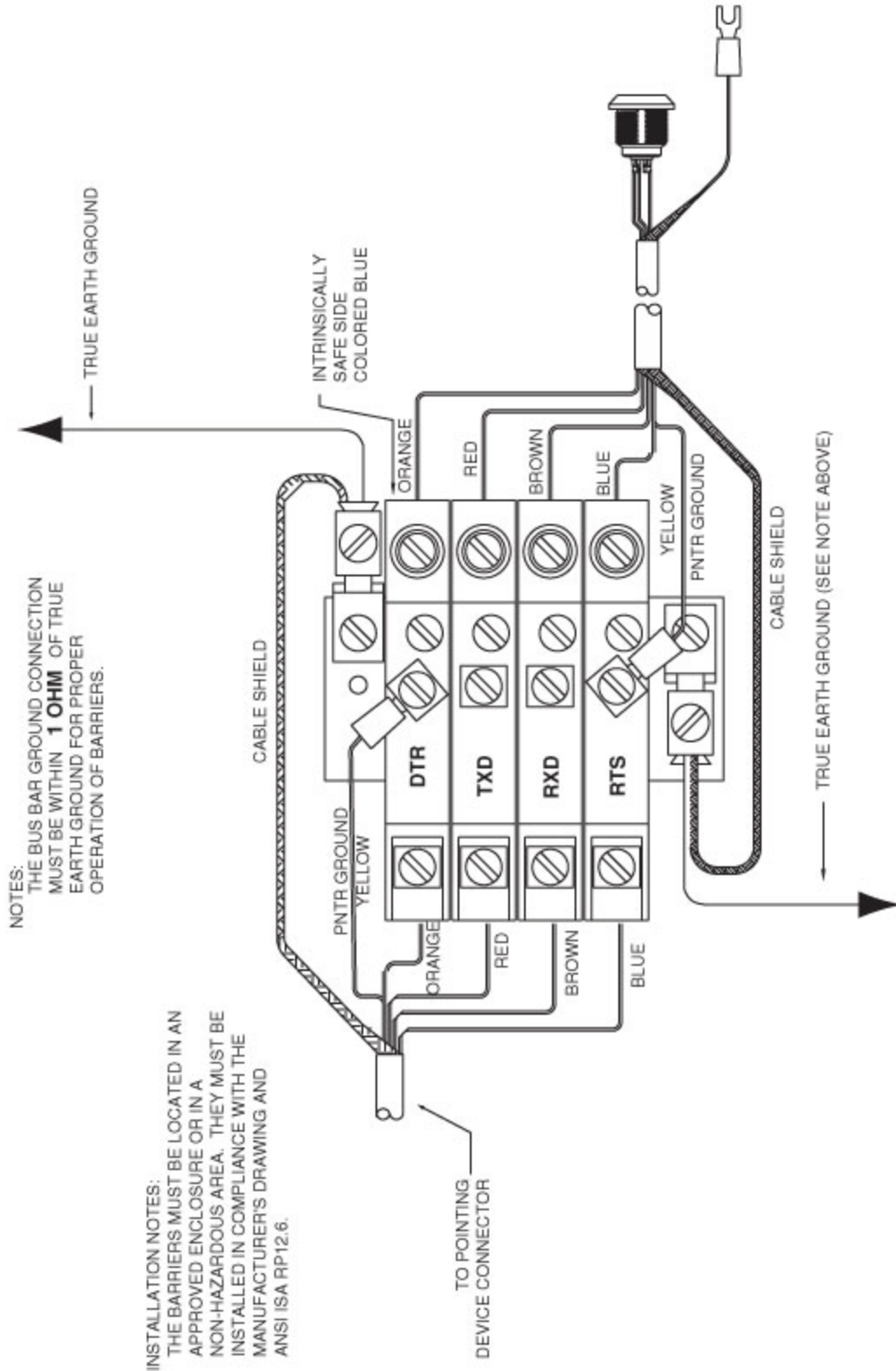

Figure 6-7 I.S. Pointer Barriers (Serial) Installed in Enclosure

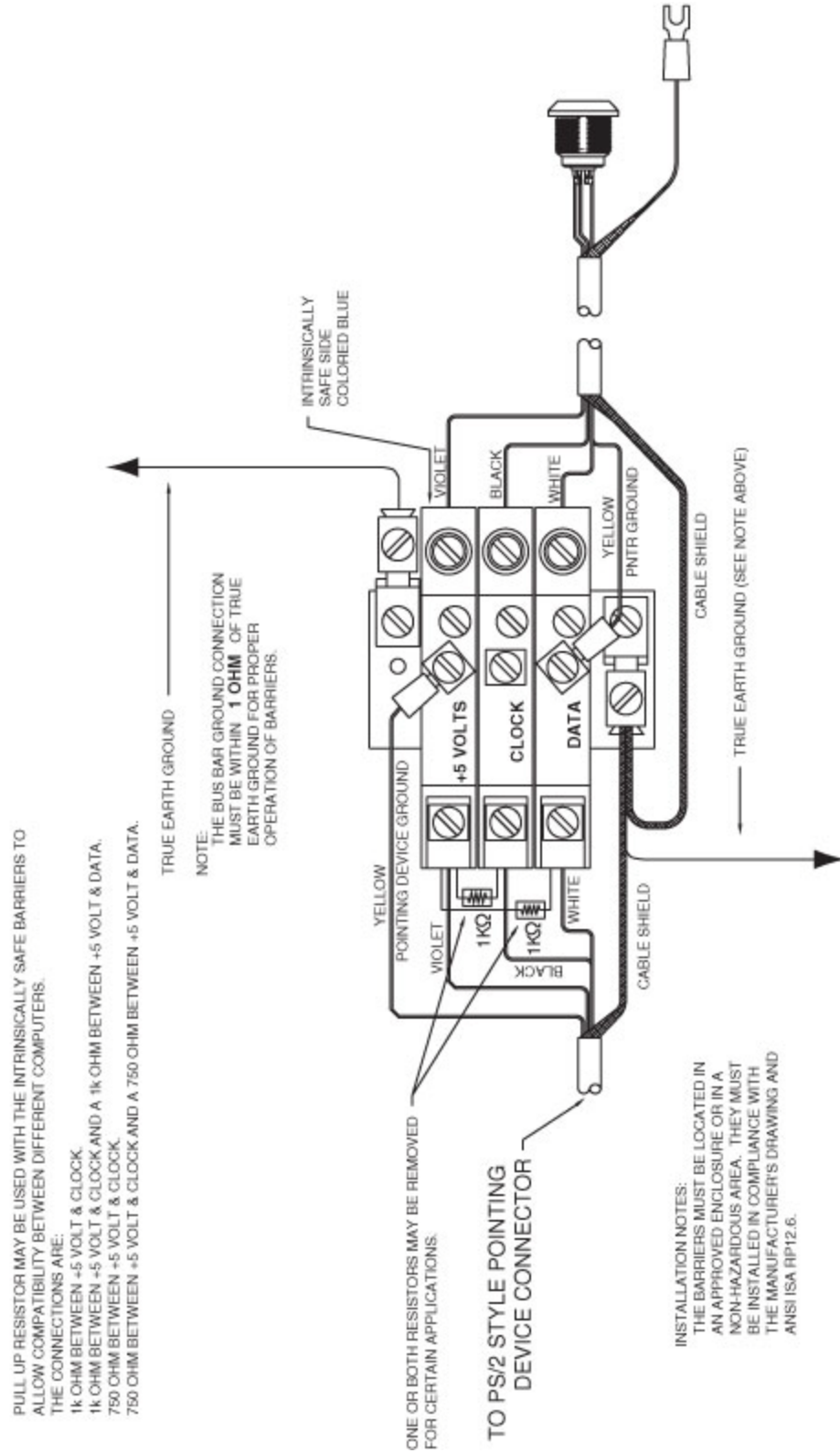

Figure 6-8 I.S. Pointer Barriers (PS/2) Installed in Enclosure

6.6. Appendix F – PS/2 Barrier Modifications for Compatibility Issues

As noted in section 2.2 on page 6, some computers' PS/2 interfaces are sensitive to the changes in impedance introduced by intrinsic safety barriers. If your intrinsically safe keyboard or pointing device is connected via a PS/2 interface and will not operate, it may be due to this sensitivity. Remediating this problem is simply a matter of changing the pull up resistors on the barriers until a working configuration is found.

The following drawings diagram the various resistor configurations that have been found to work. Please note that these drawings are only meant to be indicative of the configuration of the pull-up resistors. For drawings detailing correct installation of the barriers, please see section 6.5 on page 28.

Also, note that the connectors in your intrinsic safety barrier setup may be different from those shown in these drawings. For pinouts of other connectors, see sections 6.2 and 6.3, pages 25 and 26.

6.7. Appendix G – 9148 Current Limiting Kit Drawing

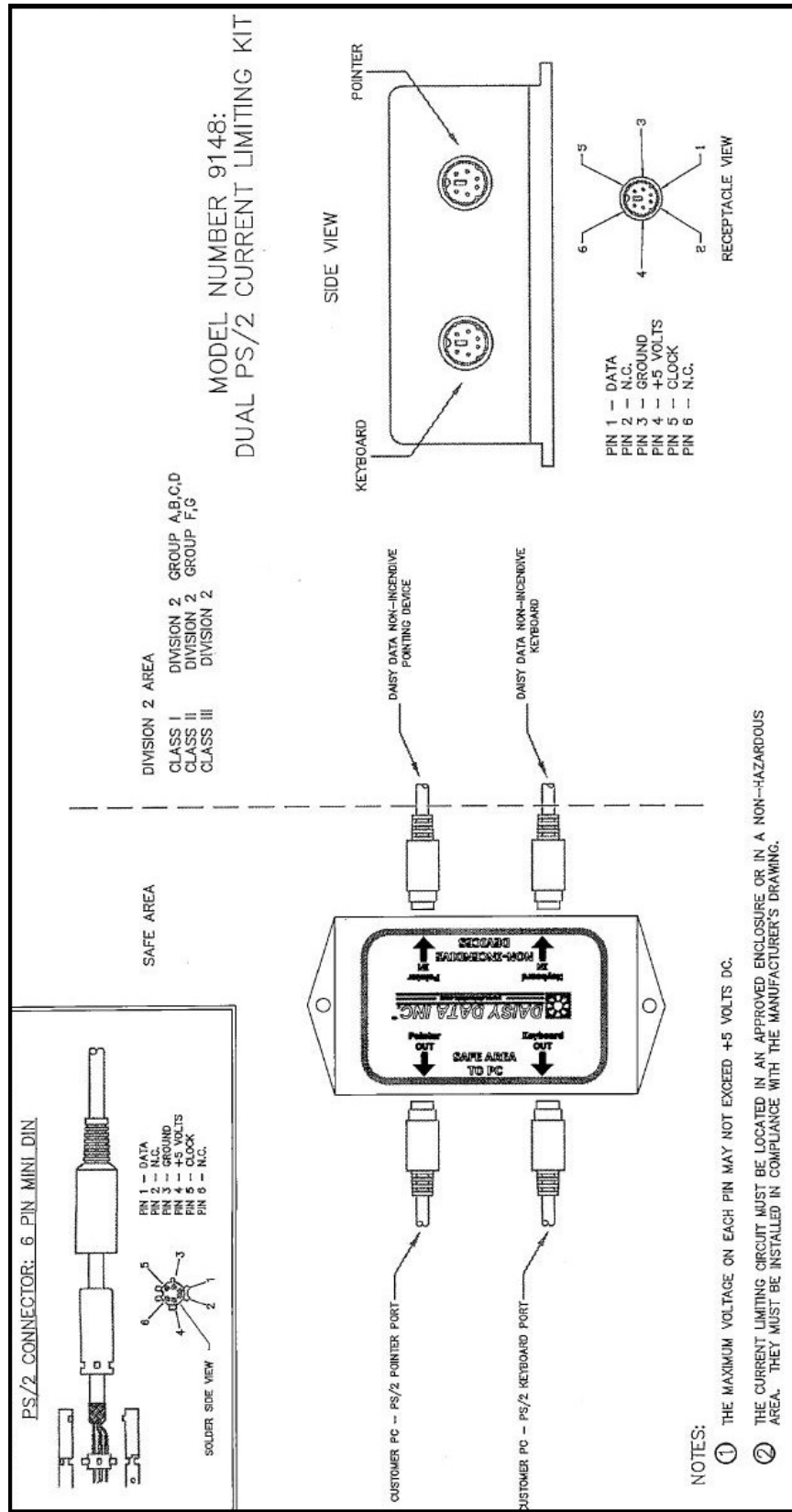

Figure 6-9 Current Limiting Kit Diagram (9148)

6.8. Appendix H – 9122 & 9141 Keyboard Isolators

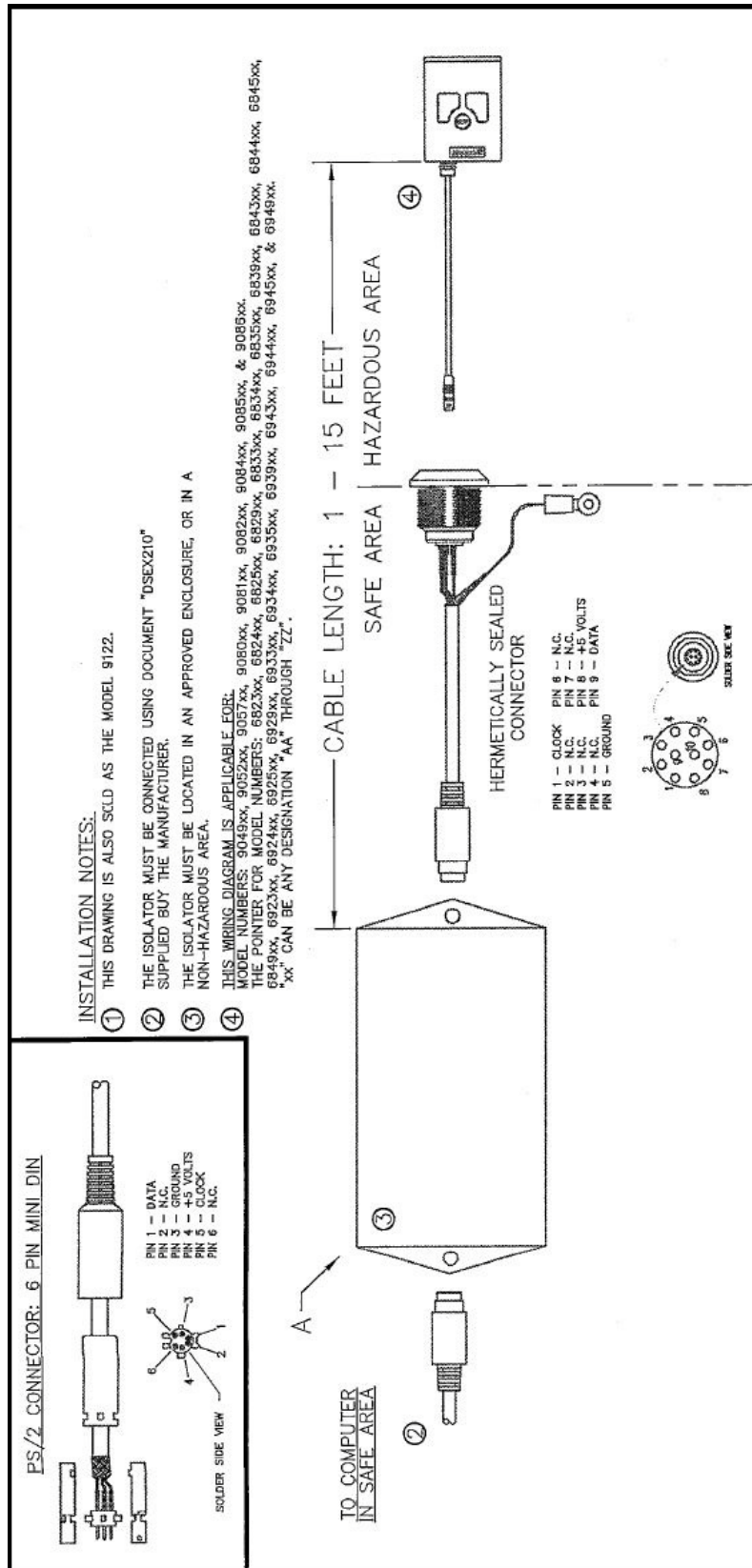

Figure 6-10 - Isolator Diagram (9122)

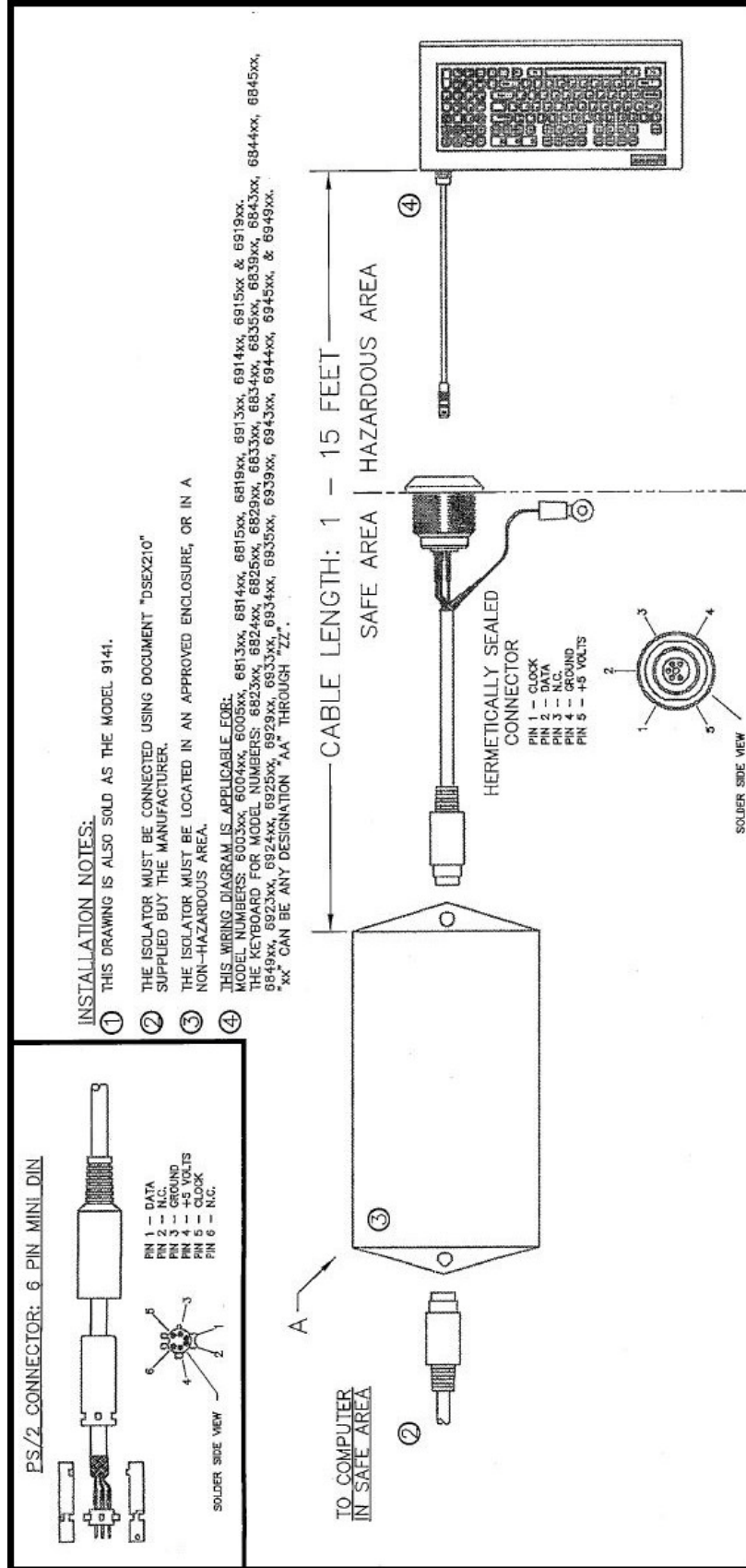
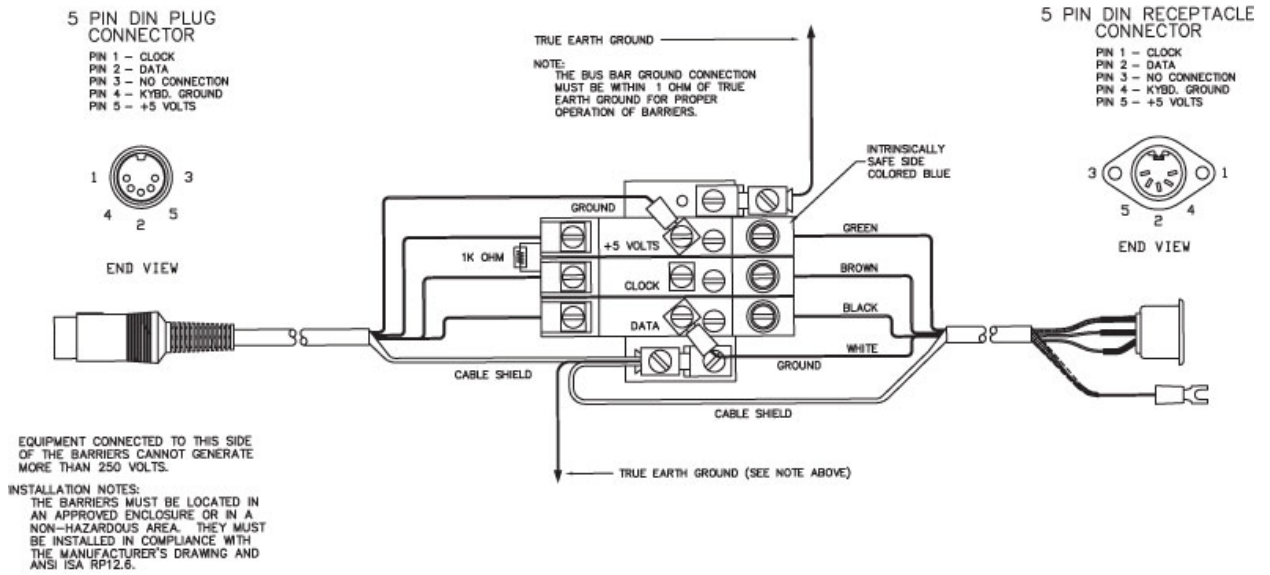

Figure 6-11 Isolator Diagram (9141)

APPLICATION #1



APPLICATION #2

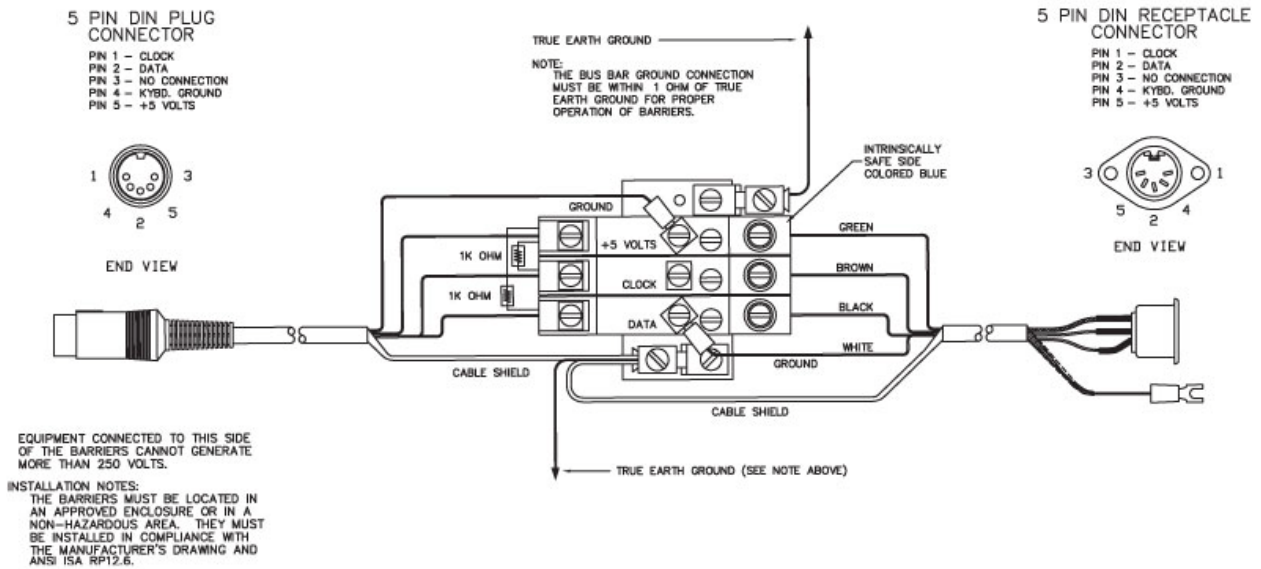
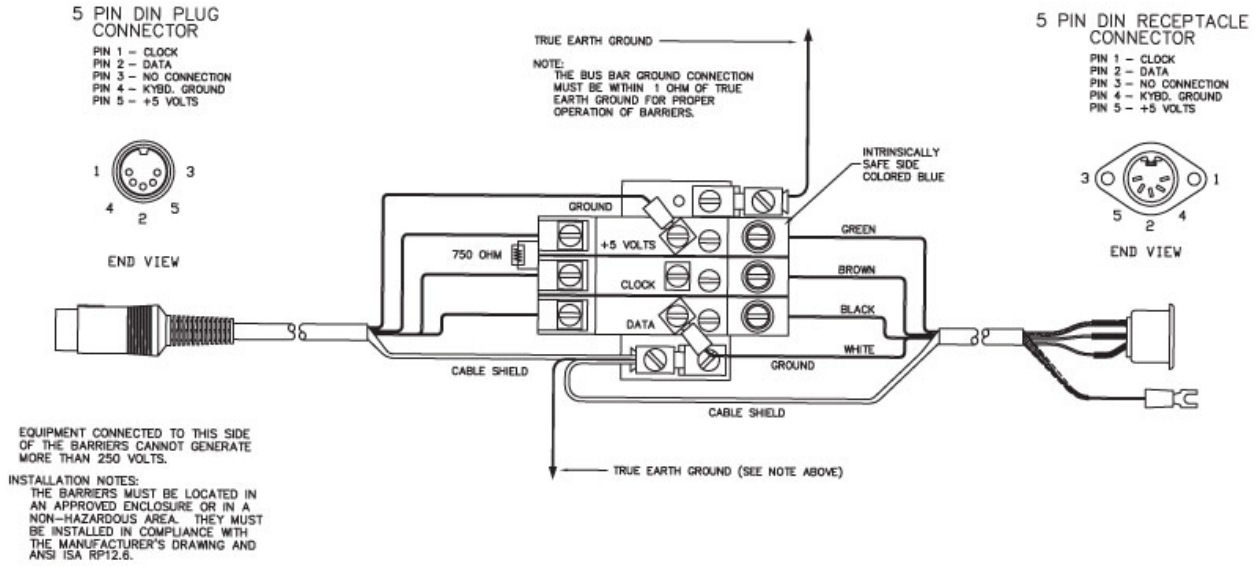

Figure 6-12 Keyboard Barrier Modifications

APPLICATION #3



APPLICATION #4

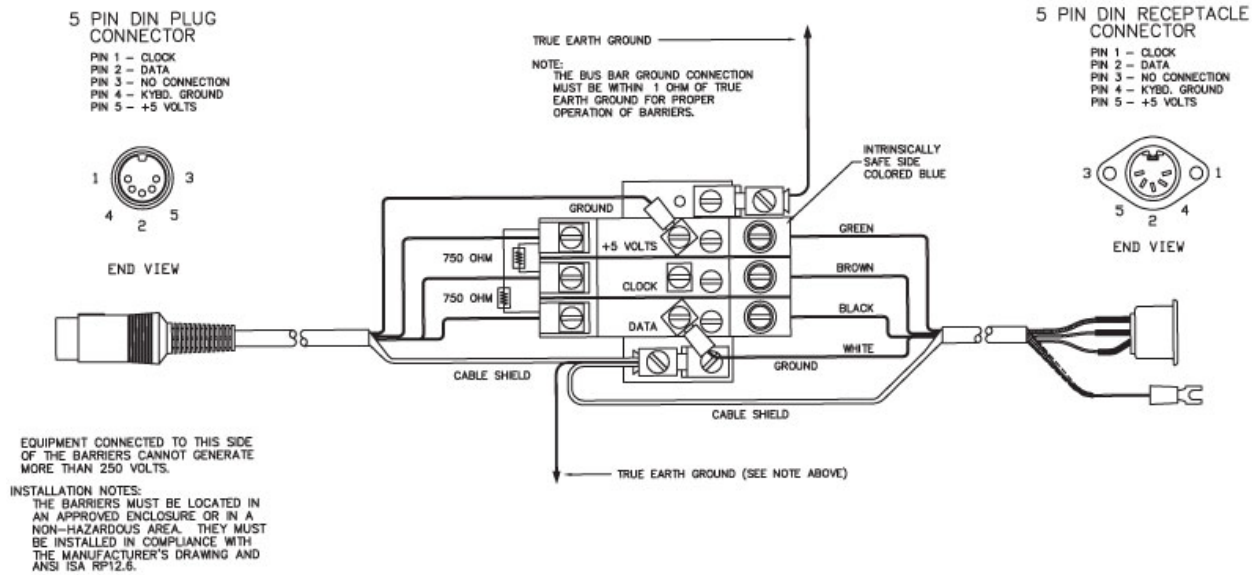
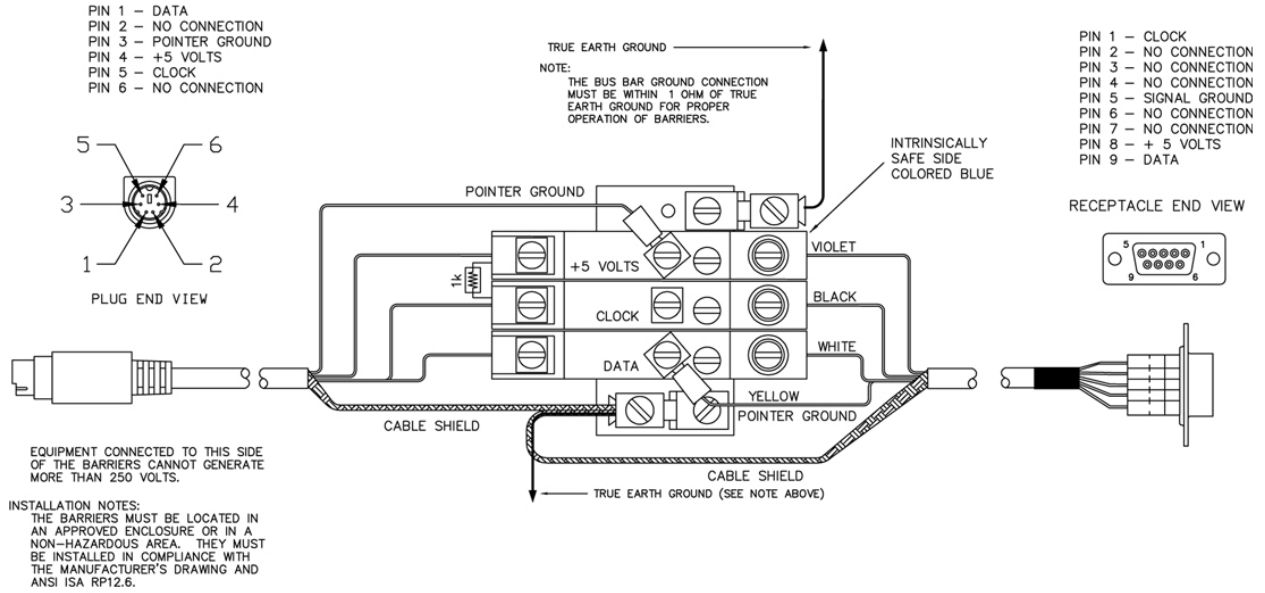

Figure 6-13 Keyboard Barrier Modifications

APPLICATION #1



APPLICATION #2

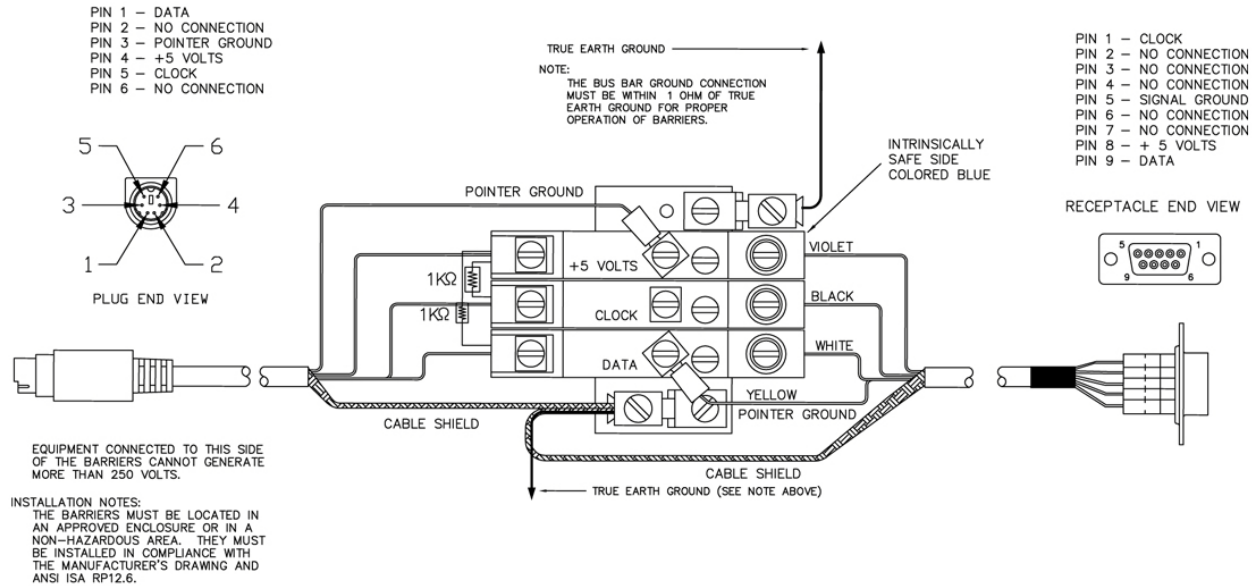
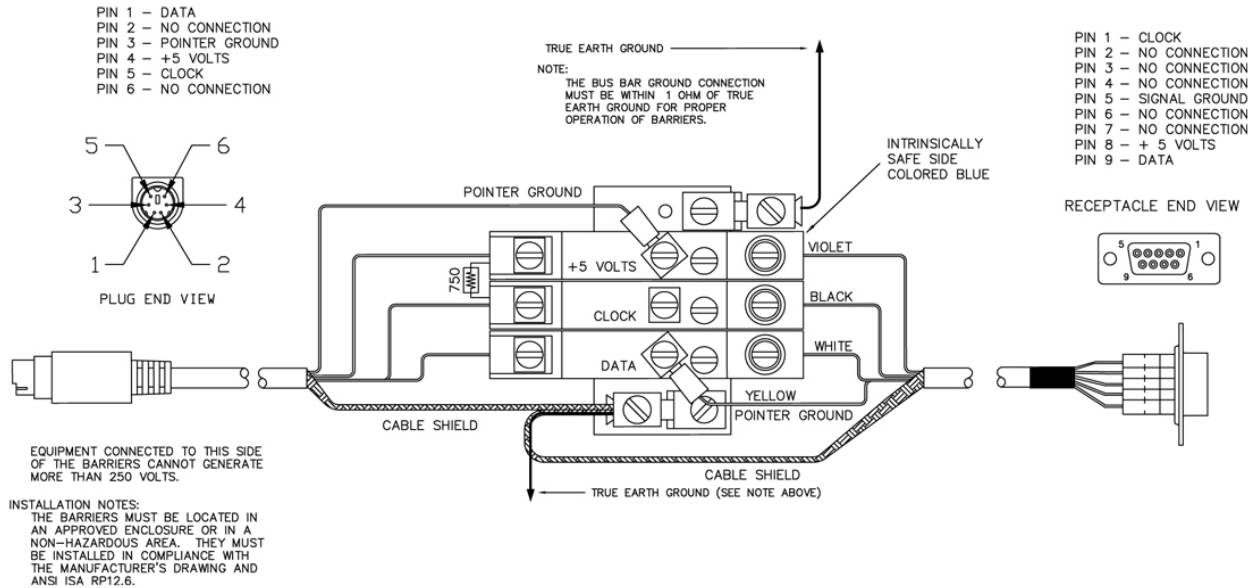

Figure 6-14 Pointing Device Barrier Modifications

APPLICATION #3



APPLICATION #4

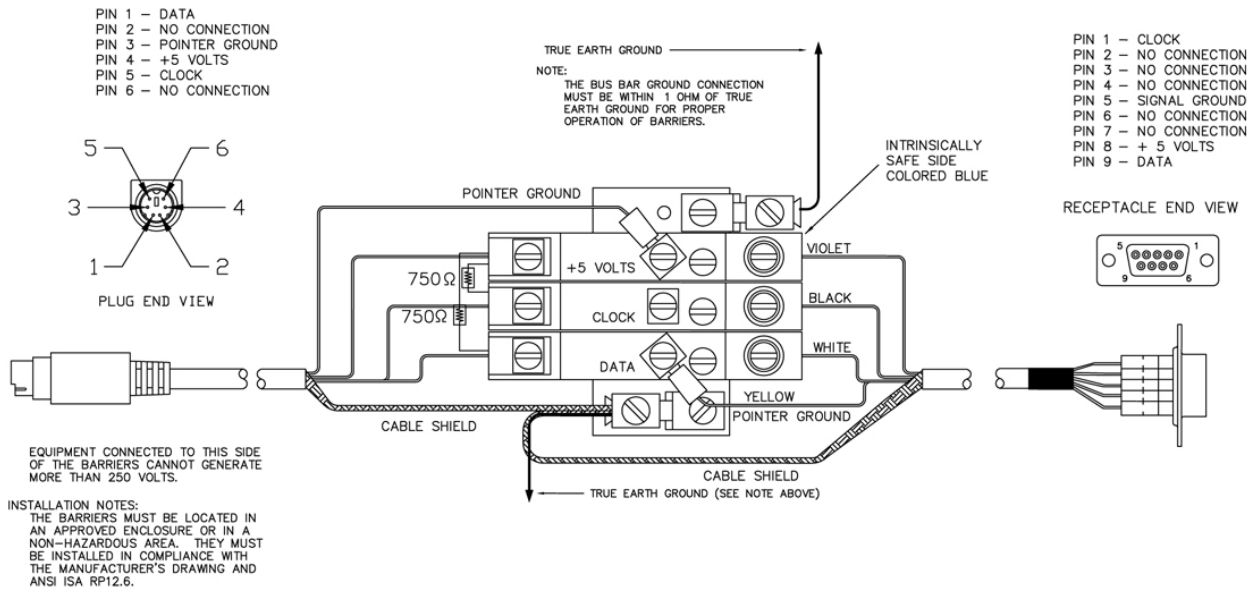

Figure 6-15 Pointing Device Barrier Modifications

6.9. Appendix I – Keyboard Model Illustrations

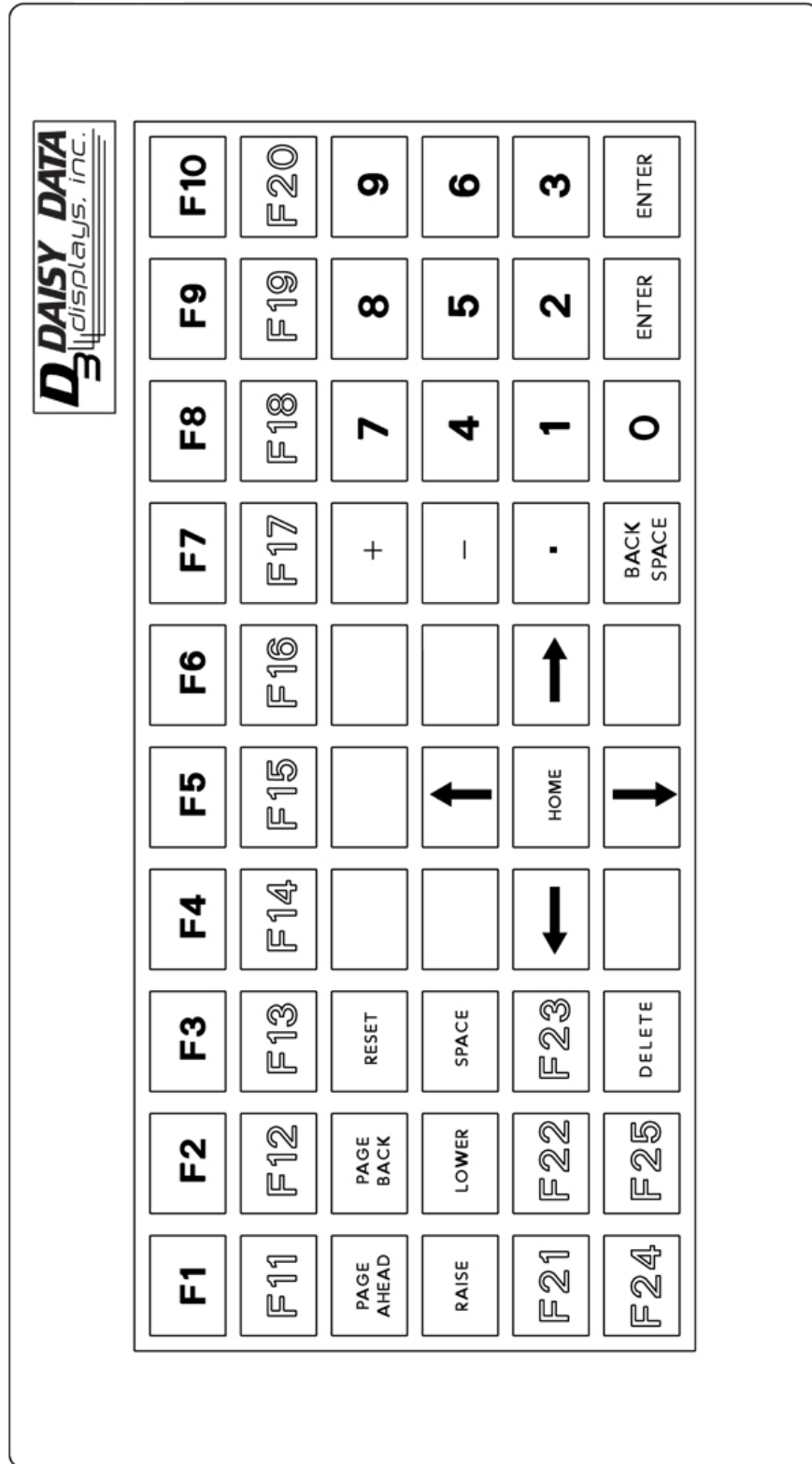

Figure 6-16 Illustration: 6000 / 6003

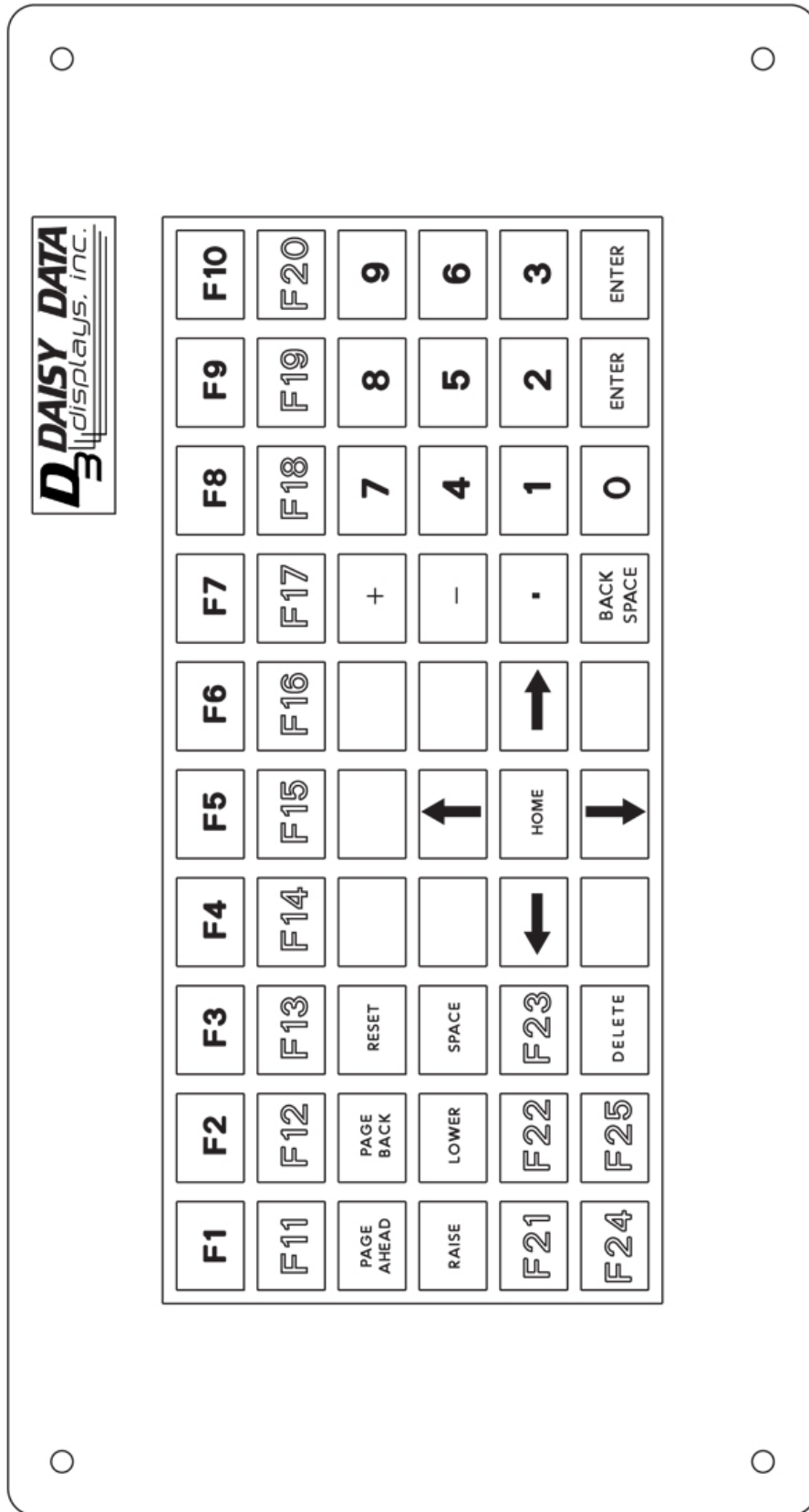

Figure 6-17 Illustration: 6002 / 6005

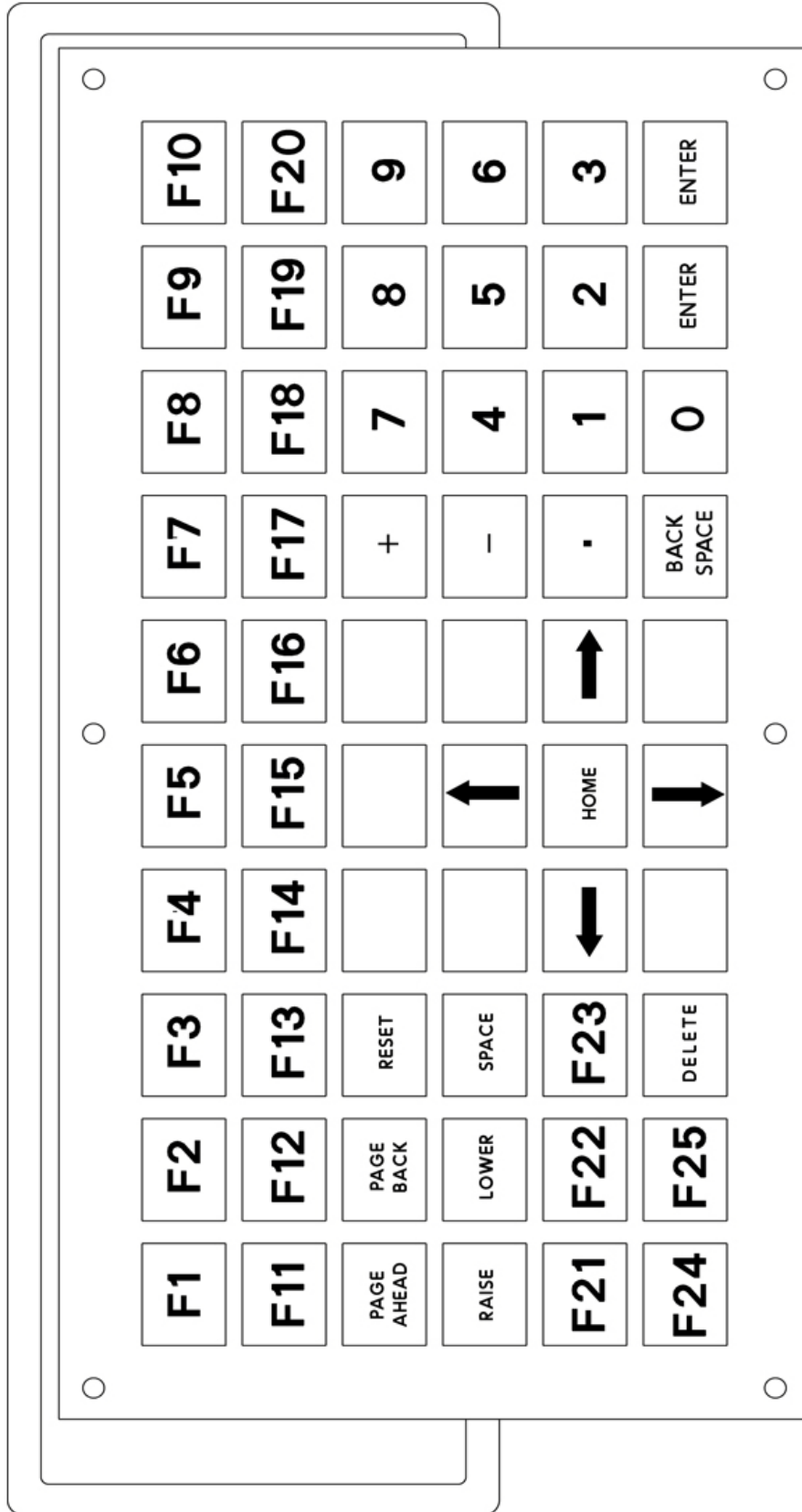

Figure 6-18 Illustration: 6002AM / 6005AH OEM Kits

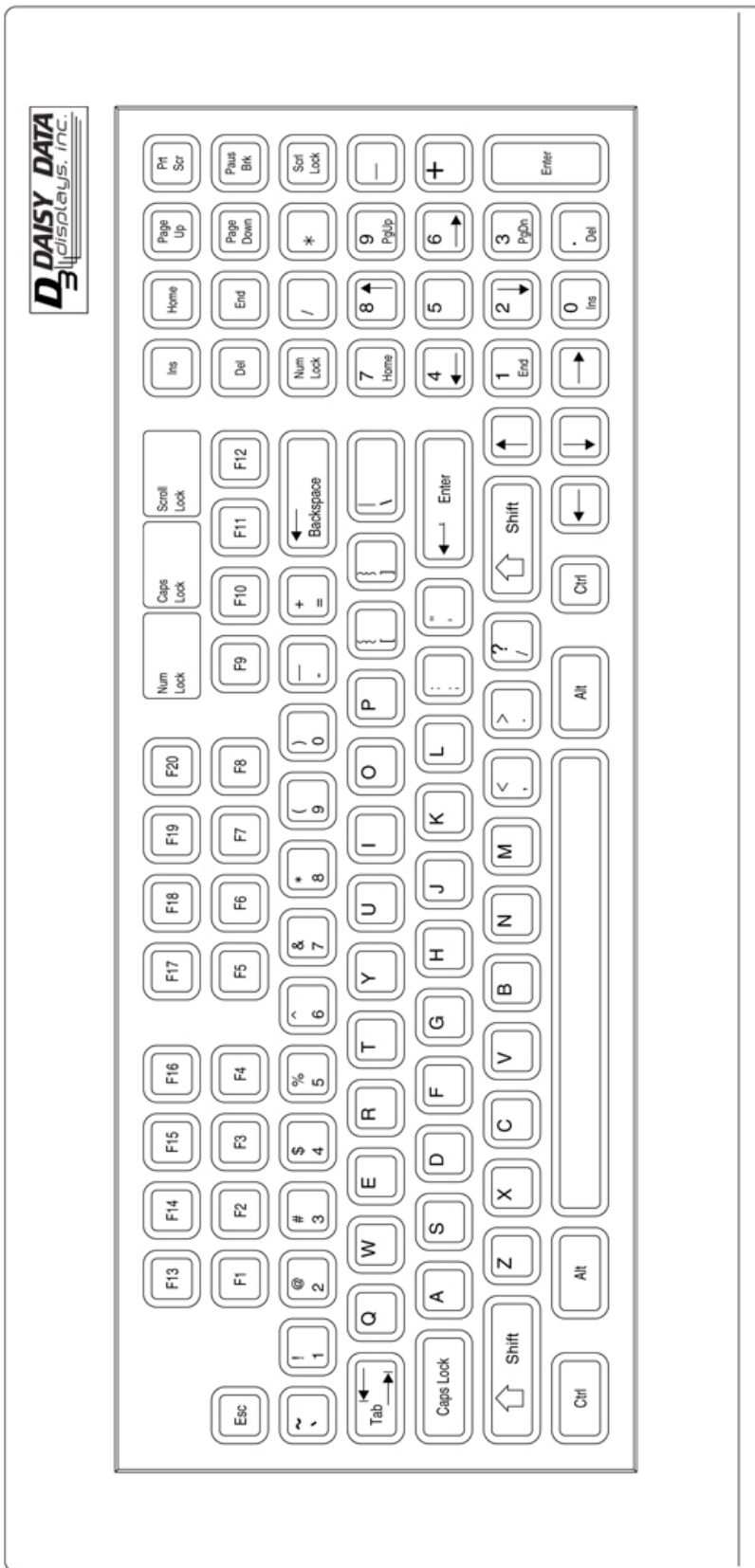

Figure 6-19 Illustration: 6810 / 6813

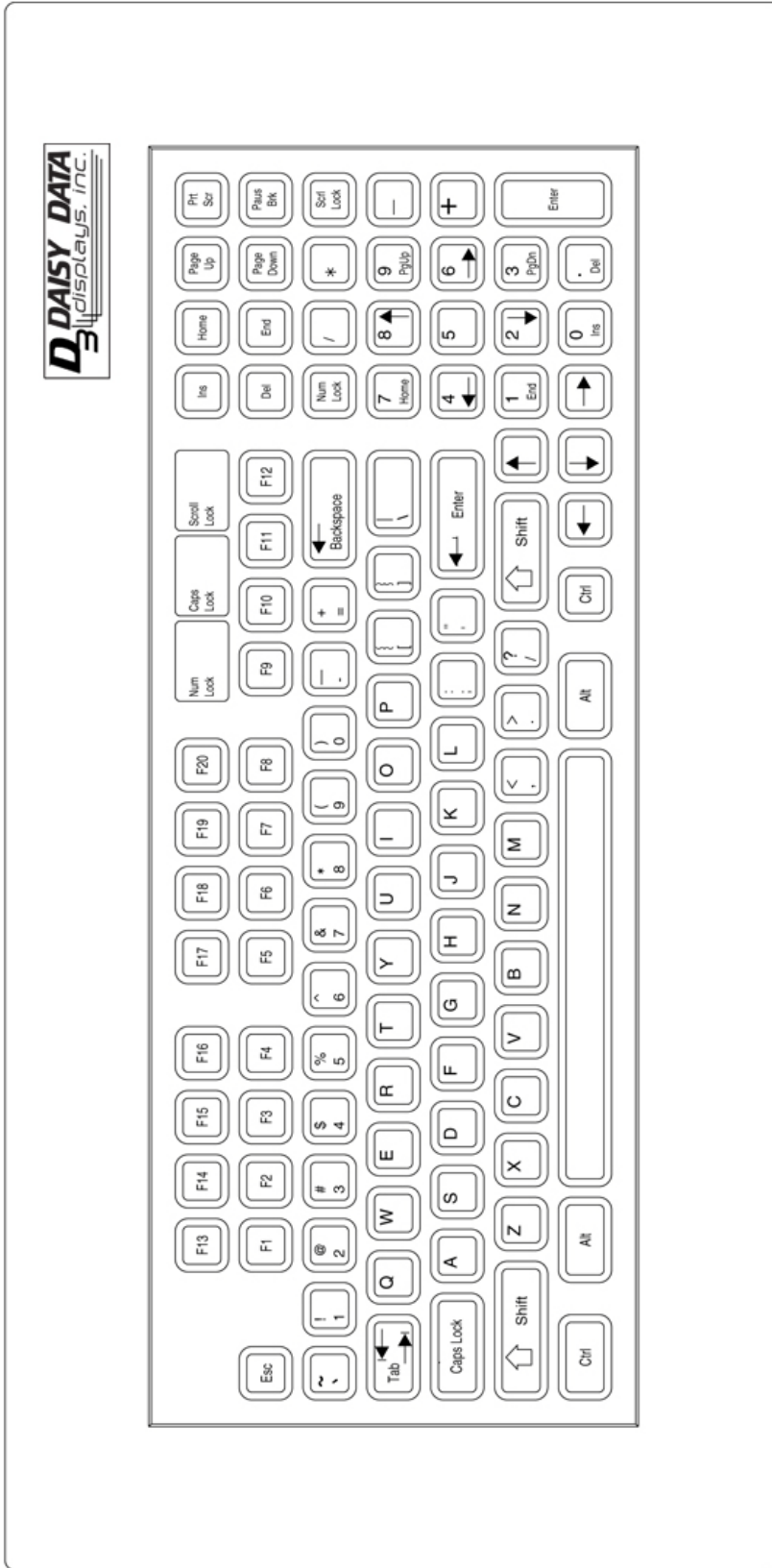

Figure 6-20 Illustration: 6812 / 6815

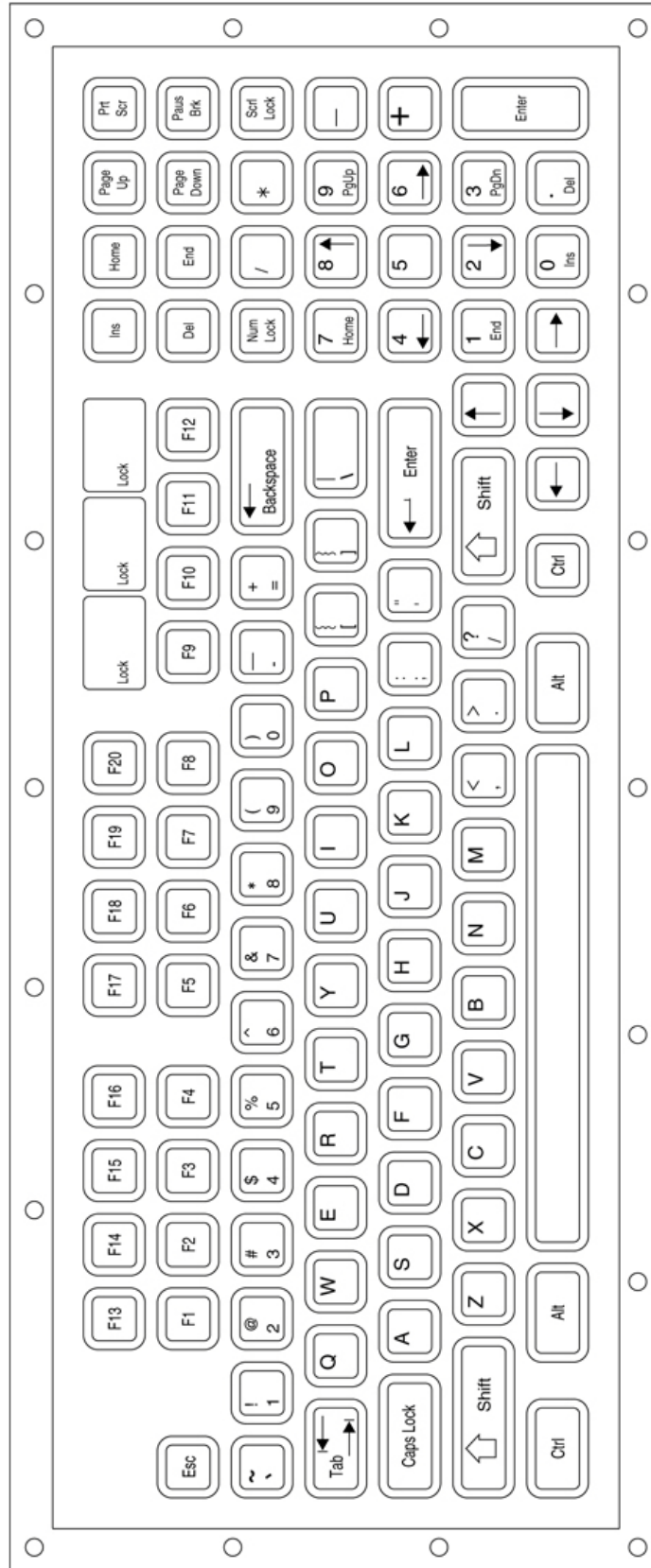

Figure 6-21 Illustration: 6812AA / 6815AA OEM Kits

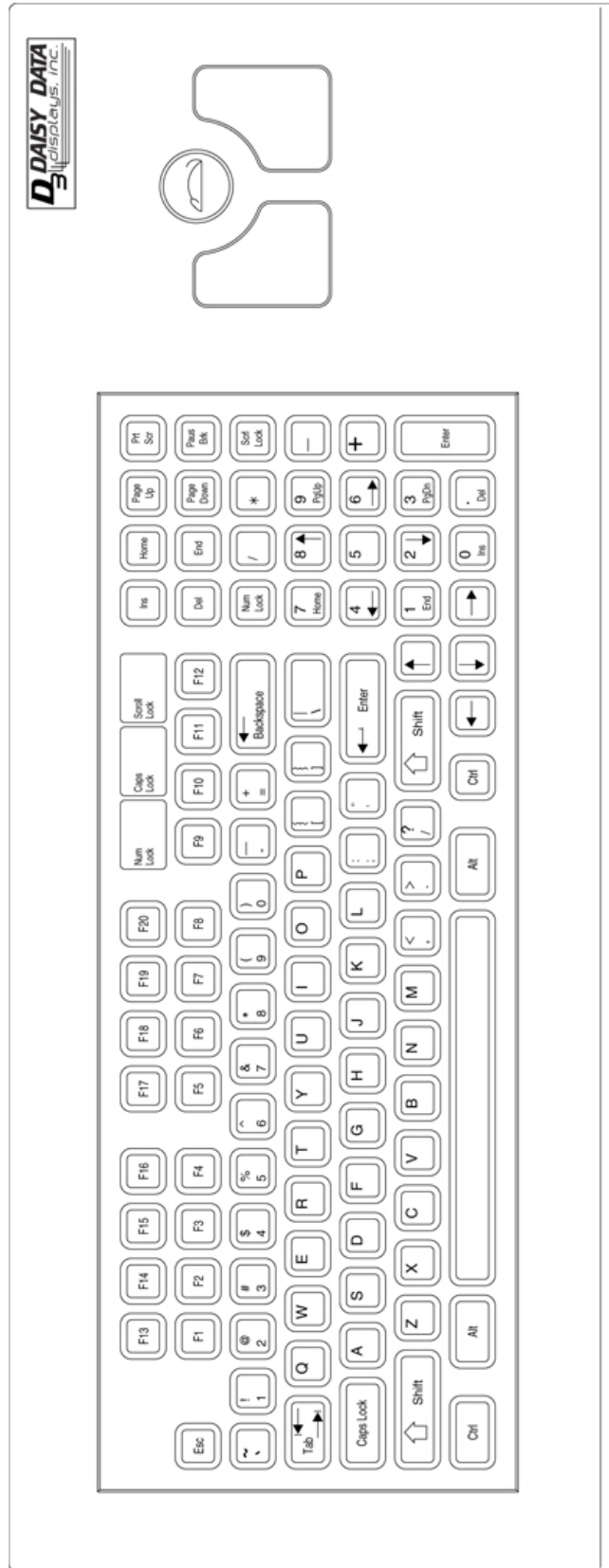

Figure 6-22 Illustration: 6820UN / 6823UN

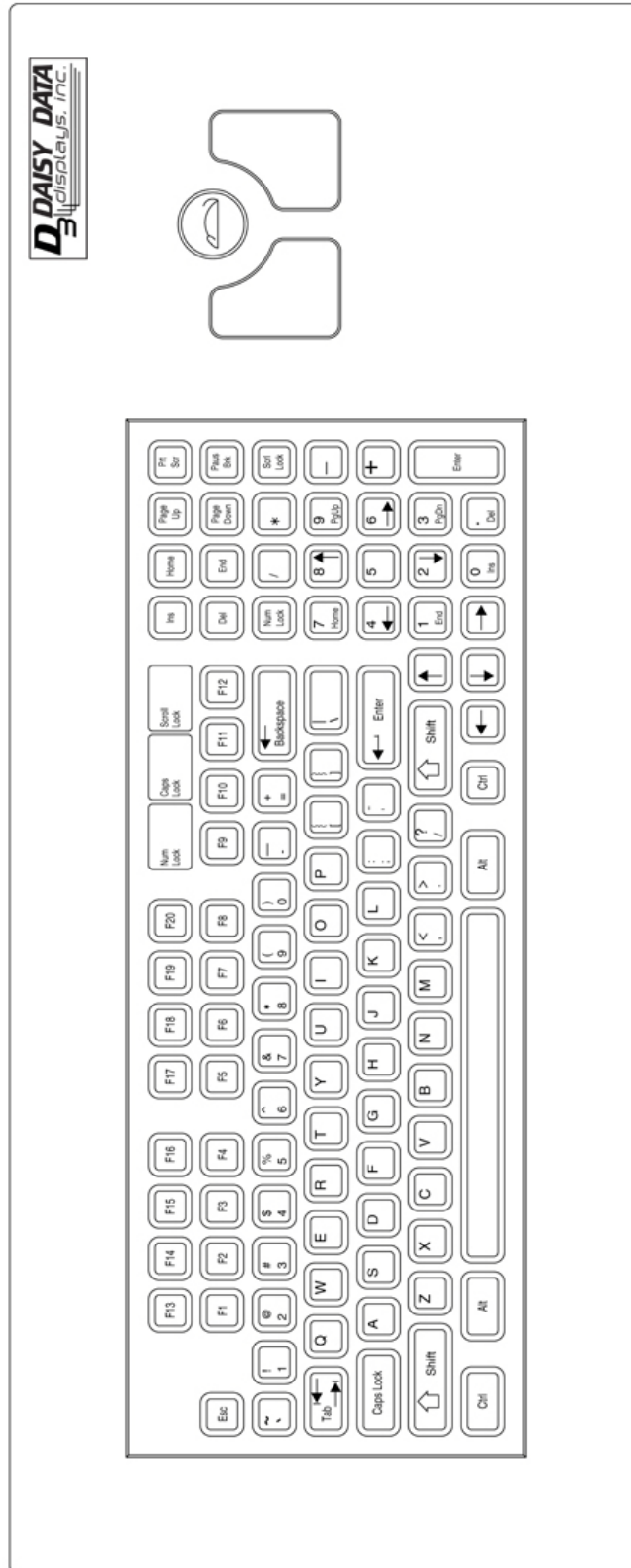

Figure 6-23 Illustration: 6822UN / 6825UN

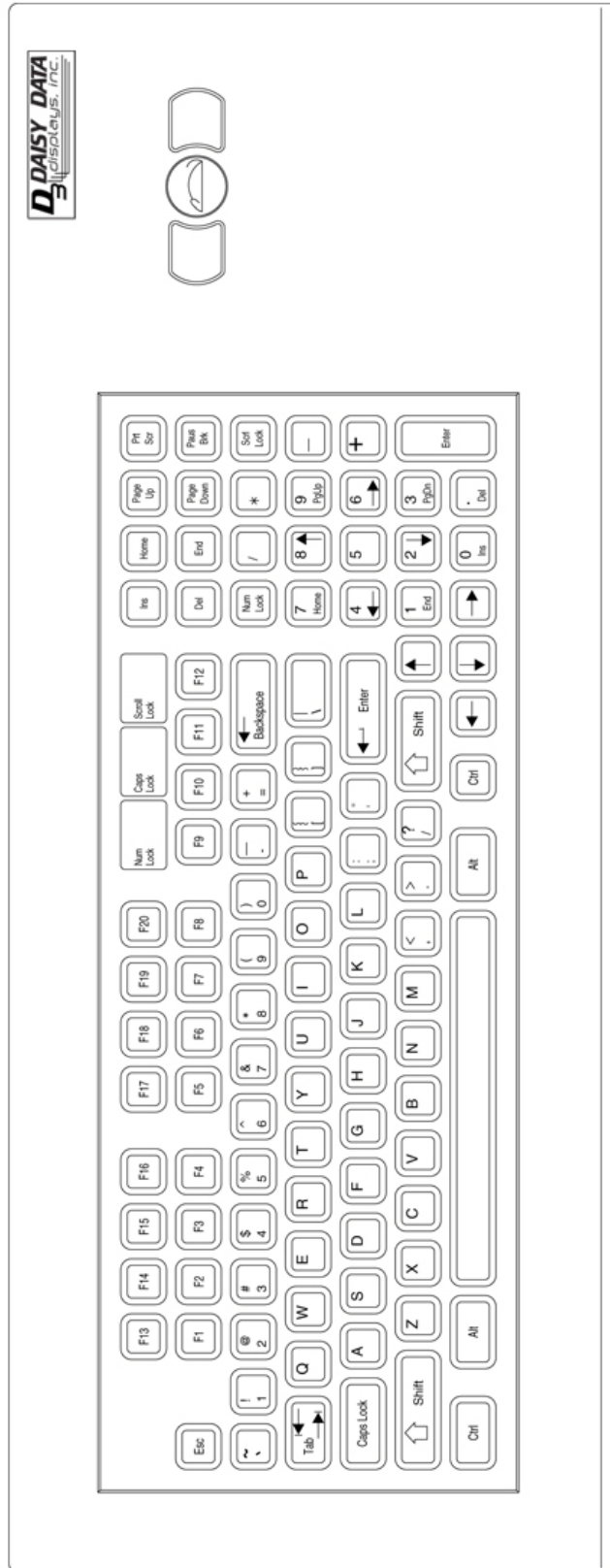

Figure 6-24 Illustration: 6830UN / 6833UN

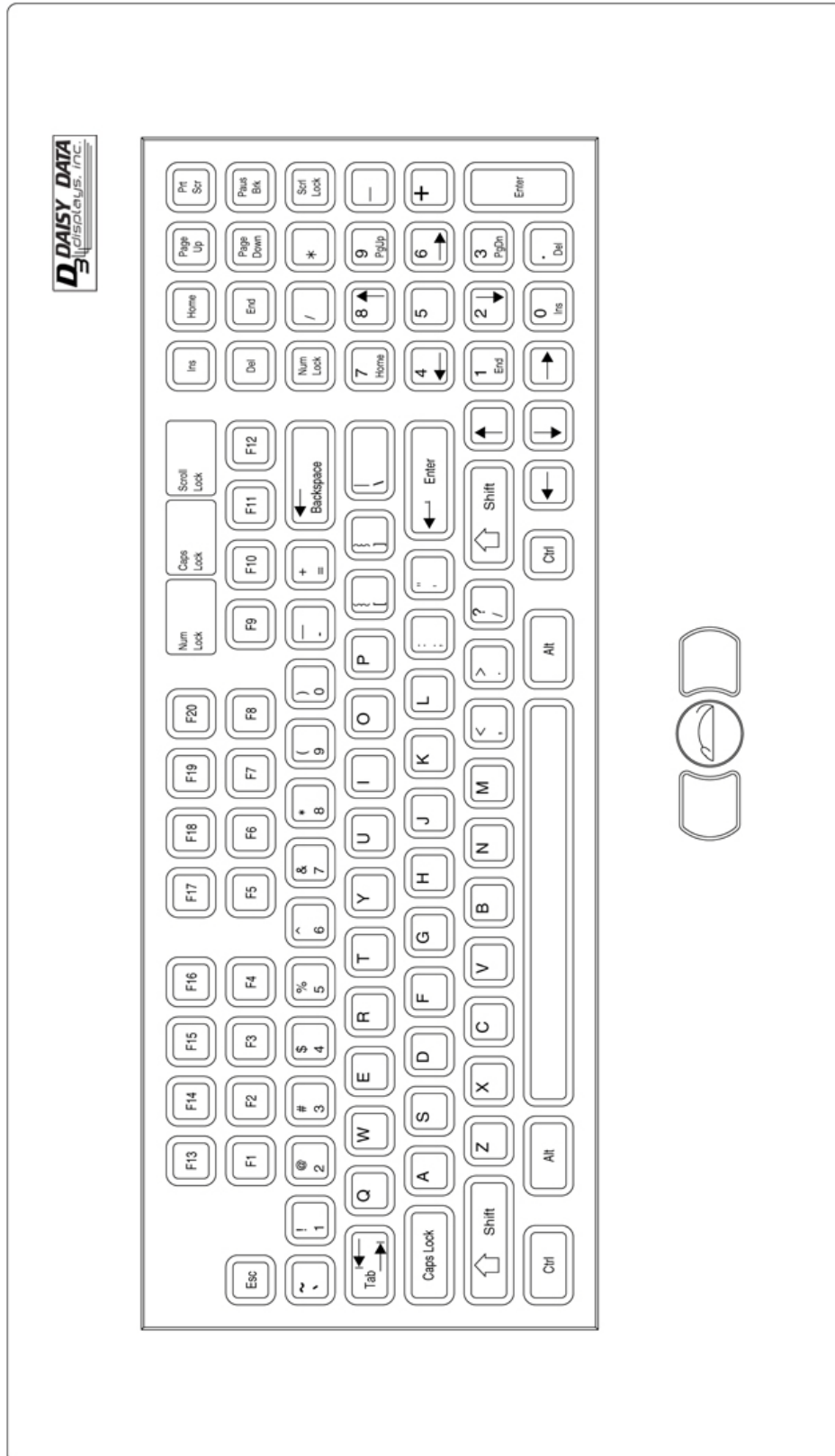

Figure 6-25 Illustration: 6832UN / 6835UN

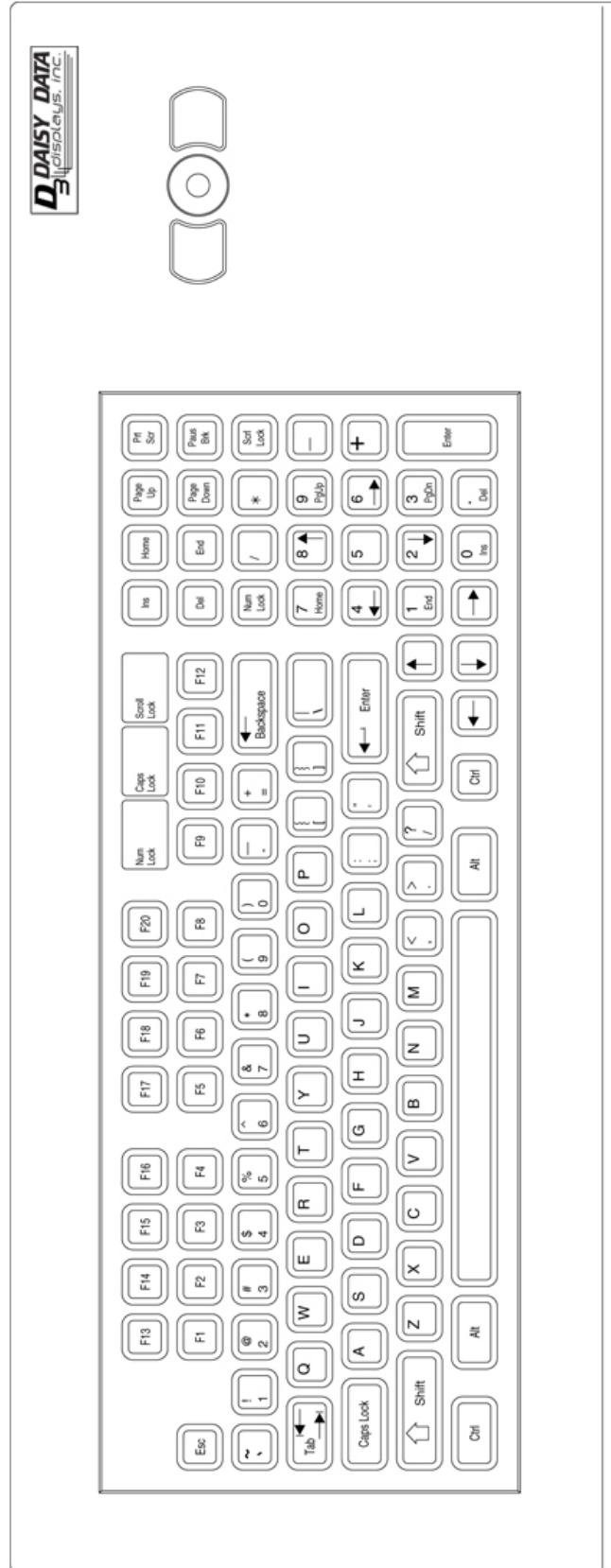

Figure 6-26 Illustration: 6840UN / 6843UN

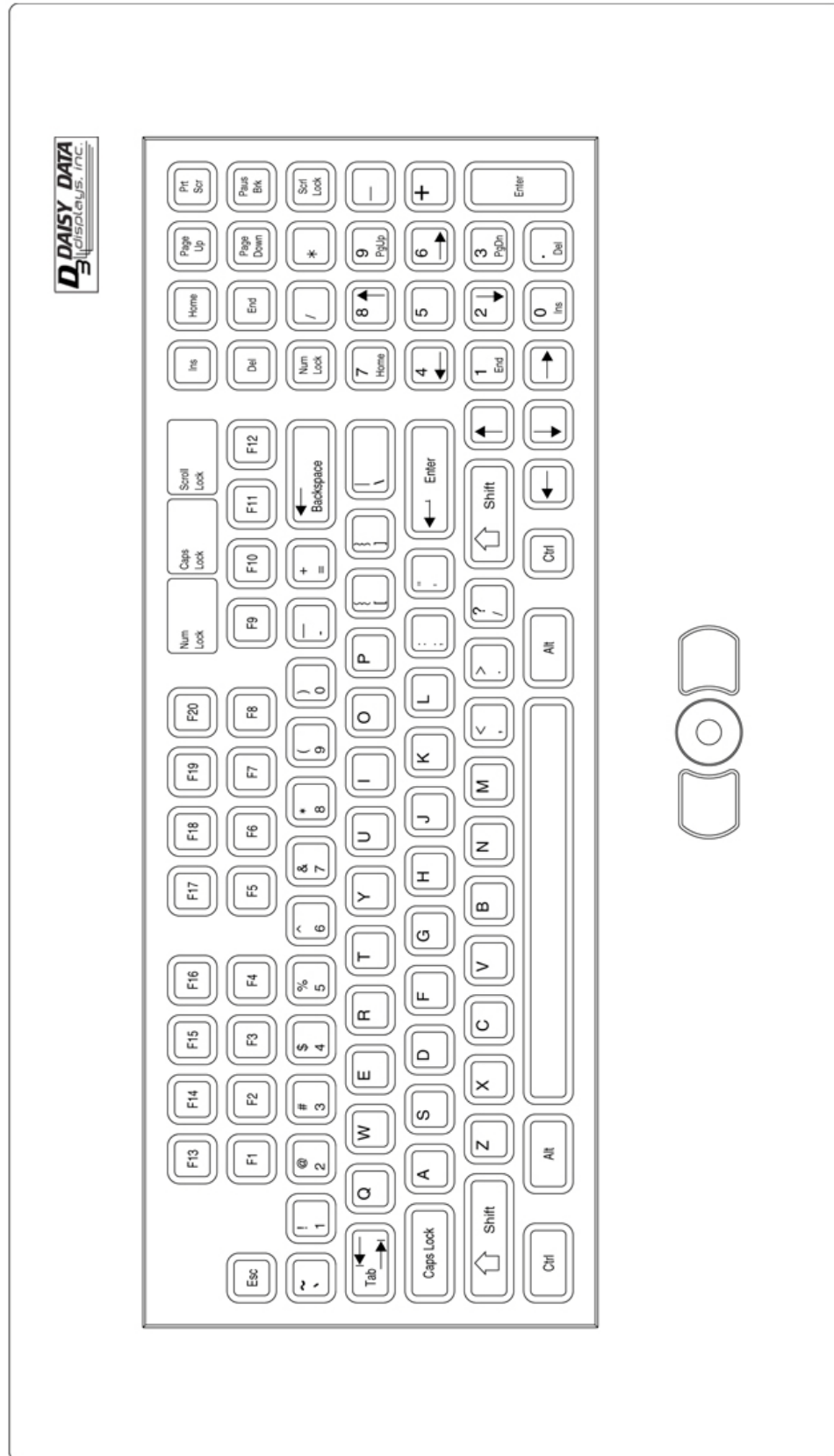

Figure 6-27 Illustration 6842UN / 6845UN

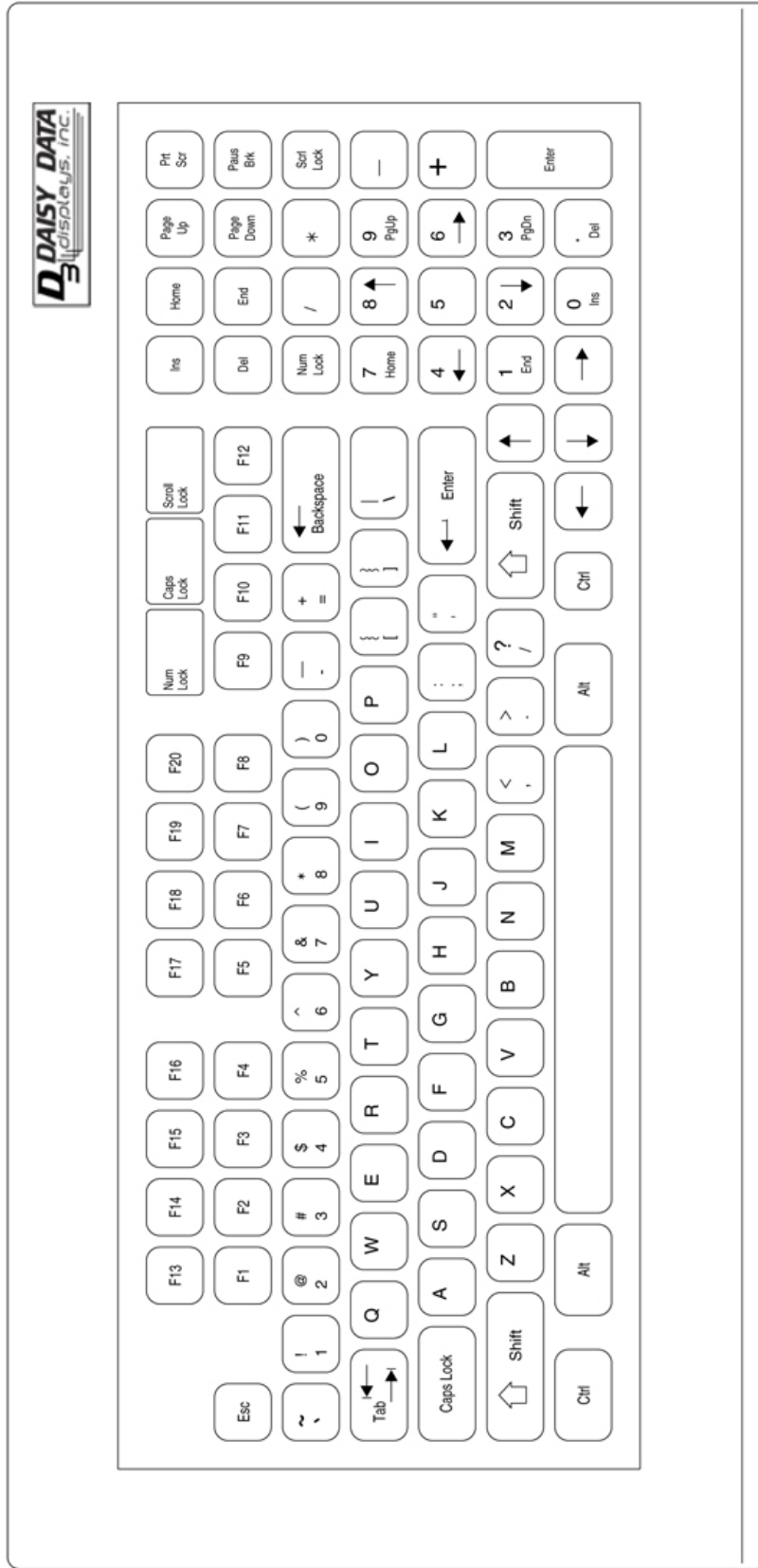

Figure 6-28 Illustration: 6910 / 6913

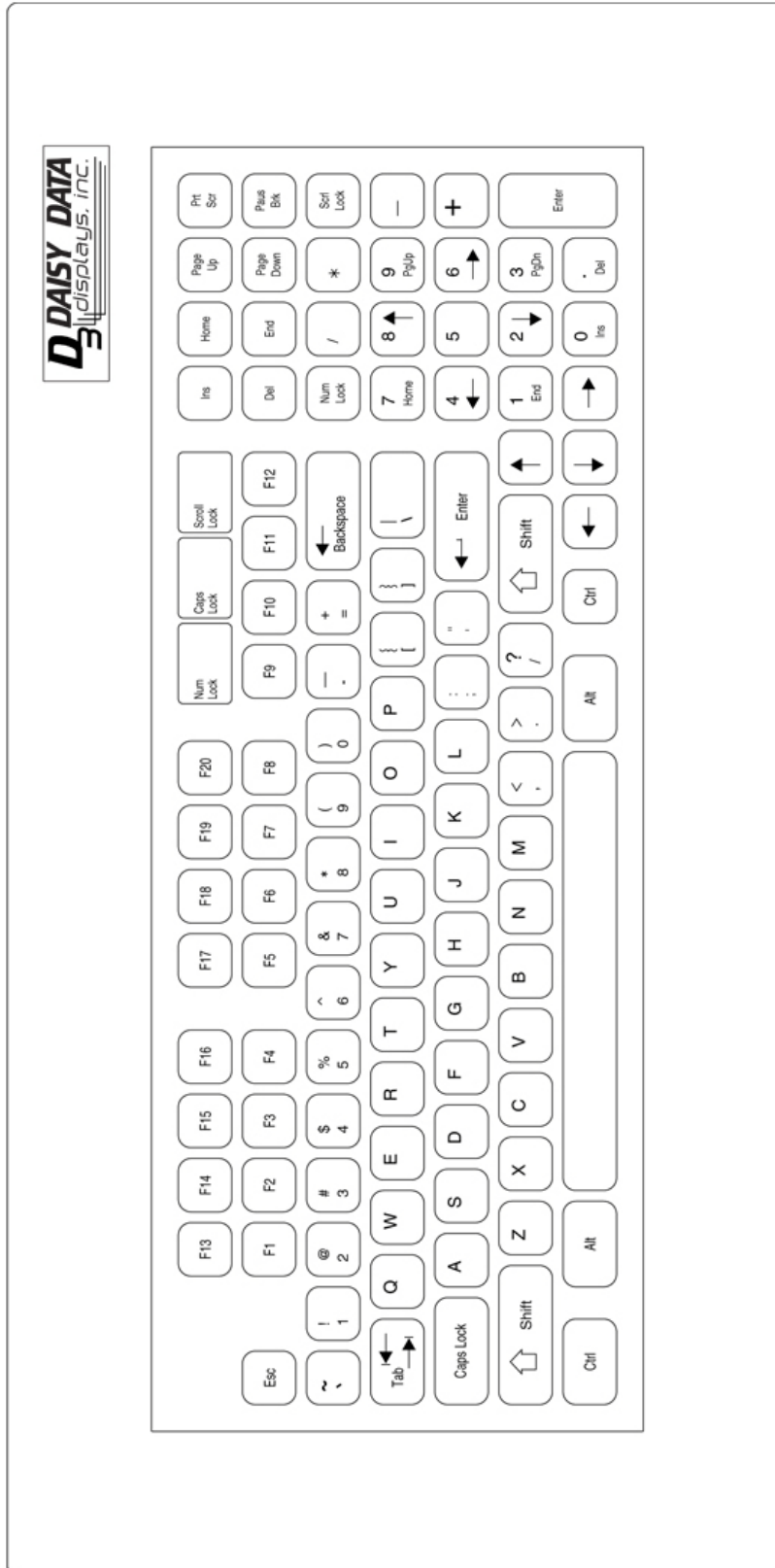

Figure 6-29 Illustration: 6912 / 6915

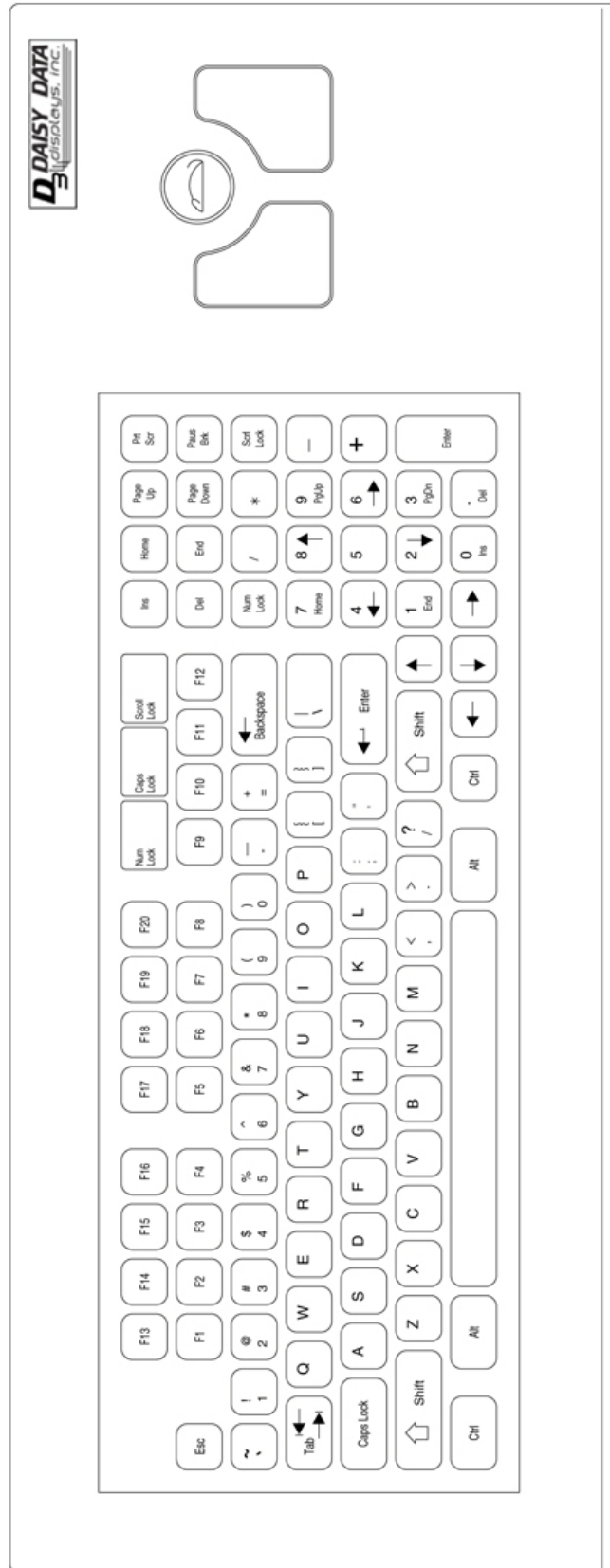

Figure 6-31 Illustration: 6920UN / 6923UN

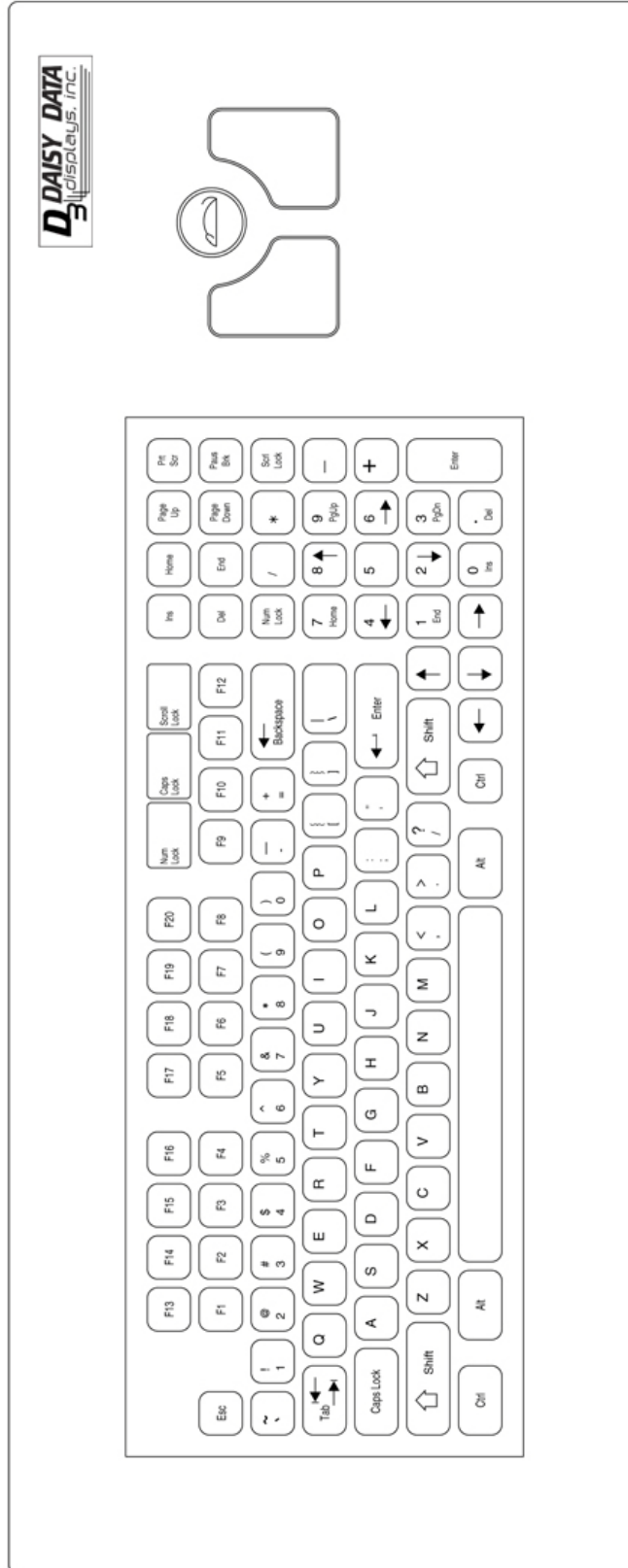

Figure 6-32 Illustration: 6922UN / 6925UN

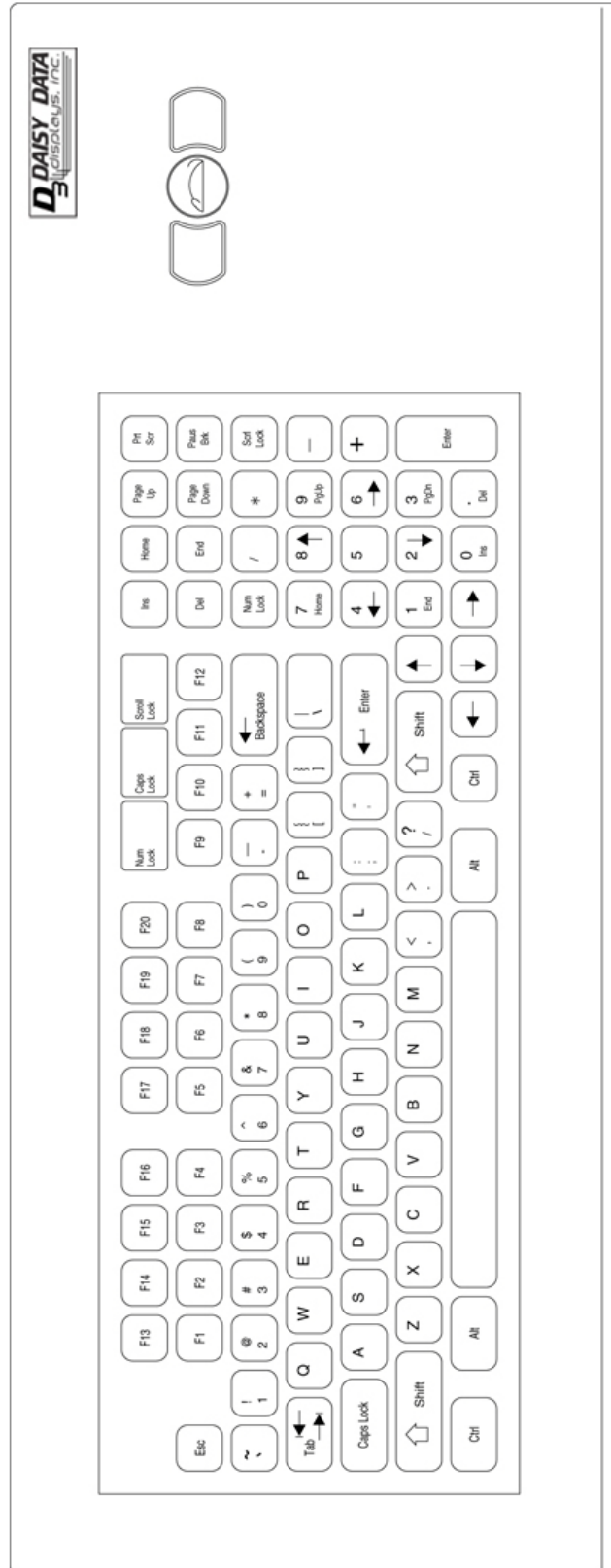

Figure 6-33 Illustration: 6930UN / 6933UN

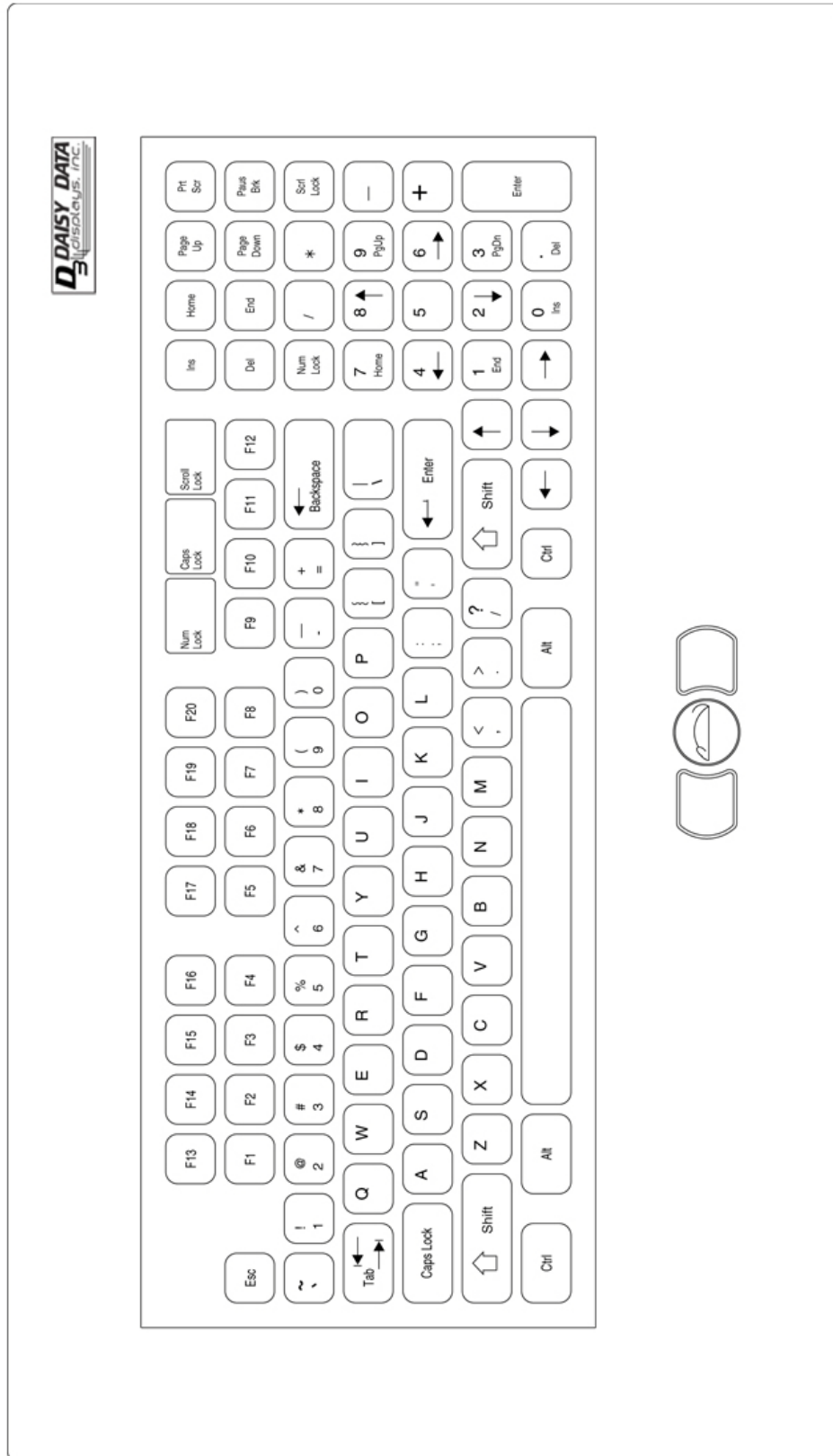

Figure 6-34 Illustration: 6932UN / 6935UN

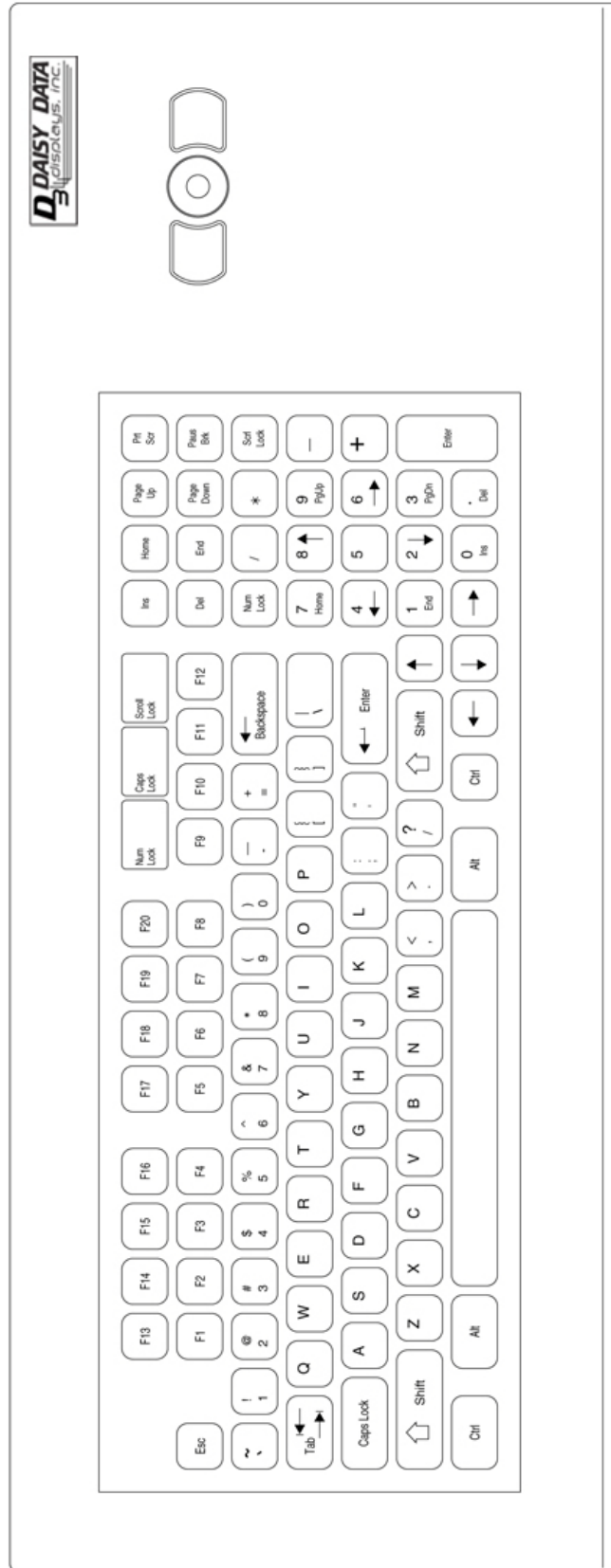

Figure 6-35 Illustration: 6940UN / 6943UN

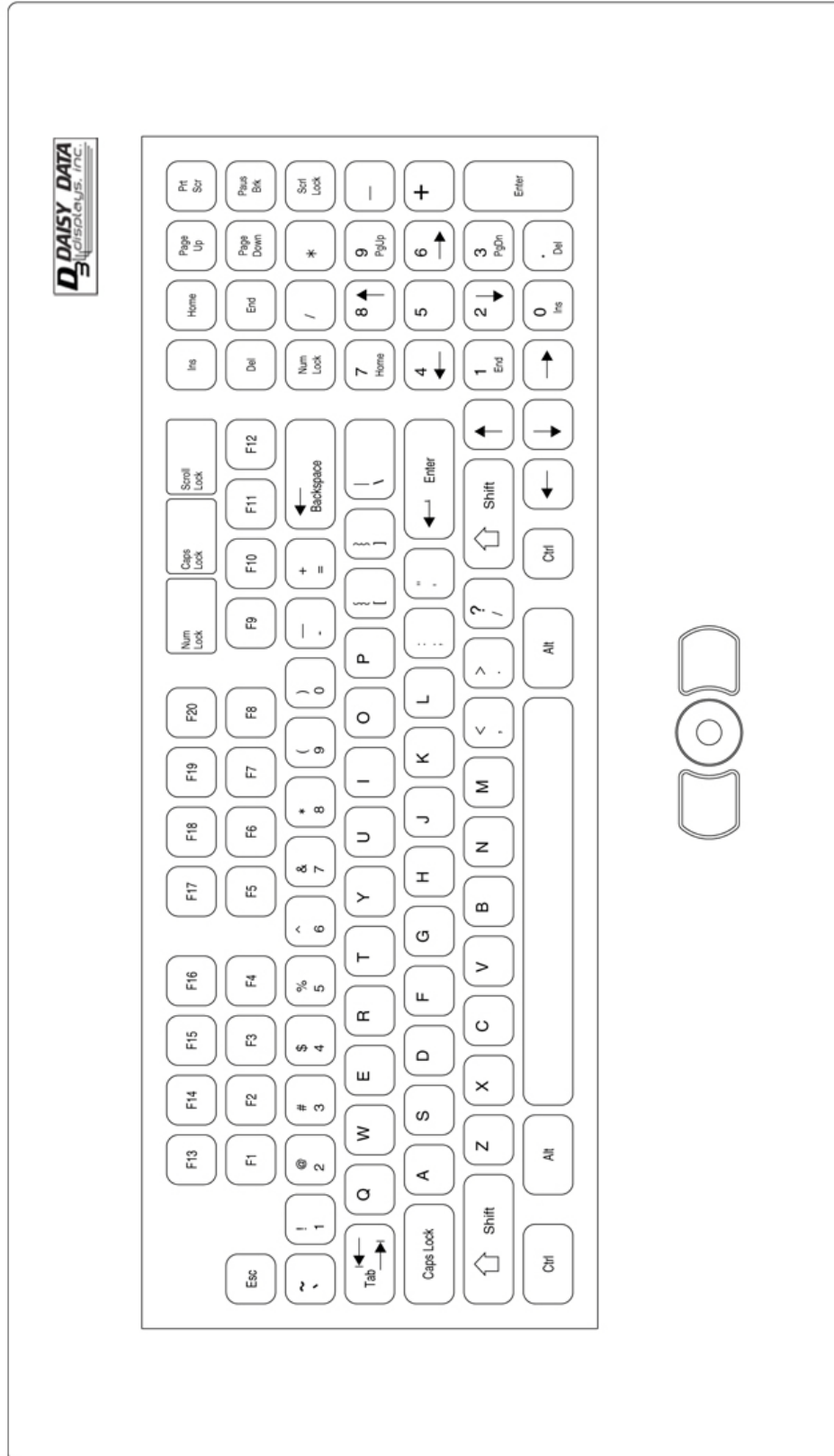

Figure 6-36 Illustration: 6942UN / 6945UN

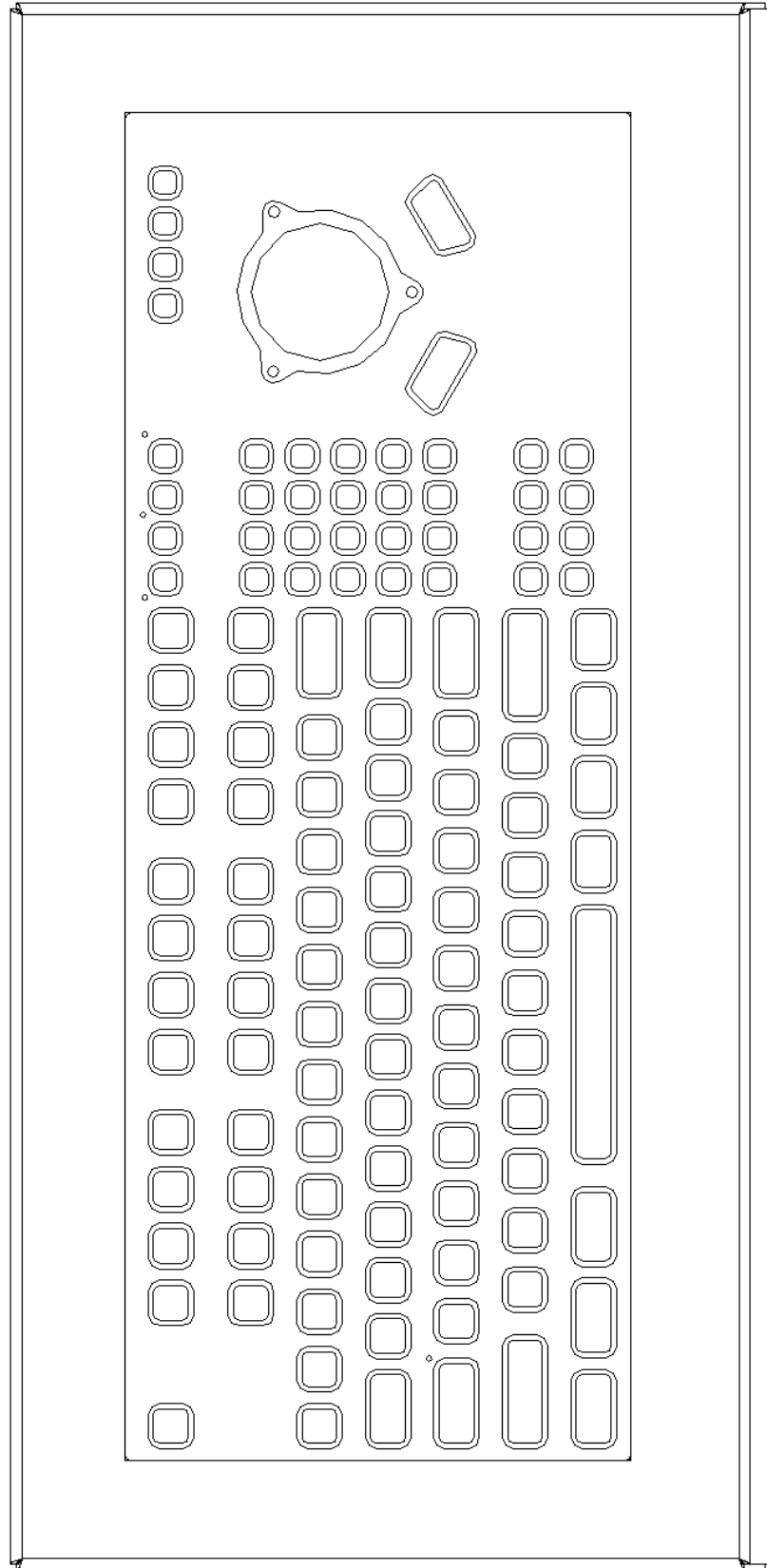

Figure 6-37 Illustration: 6950UN